

# MusiciansFriend®

June 2013



## ONEREPUBLIC'S RYAN TEDDER

The multifaceted frontman of OneRepublic on the rocky road to sweet success

INTERVIEW INSIDE

*Exclusive Savings*  
**15% OFF**  
A SINGLE ITEM \$49+  
SEE BACK COVER  
FOR COUPON & DETAILS

FEATURED GEAR

**\$20 INSTANT REBATE**

Audio-Technica  
ATH-M45 Studio  
Monitor Headphones

241606 MSRP \$150.00  
~~\$99.99~~ Before Rebate **\$79.99** After Rebate

**SAVE \$199.01**

JBL  
EON 515XT  
Powered PA Speaker

H70074 MSRP \$899.00  
~~\$699.00~~ **\$499.99**

**SAVE \$100**

forte  
Focusrite  
Forte USB Audio Interface

H88541 MSRP \$749.99  
~~\$599.00~~ **\$499.99**

**FREE SHIPPING ON ALMOST EVERYTHING** [musiciansfriend.com](http://musiciansfriend.com) 800.217.5207

# FRIEND to FRIEND

## Garage Bands Unite

When most people hear the word “garage,” they immediately think of that place where they park the car, store their camping gear and do the laundry. For musicians, however, the garage has an entirely different mission. Along with the basement, it’s a room that most musically inclined people are happy to sacrifice in order to pursue their craft. Nearly all of us have jammed in someone’s garage at some point, and know the familiar tap of a local police officer’s Maglite on the door informing us that the neighbors have had enough.

The garage isn’t just for kids honing their chops in their first band either. Dave Grohl of the Foo Fighters famously converted the garage of his Encino home to a makeshift studio to record 2011’s *Wasting Light*. The Red Hot Chili Peppers still gather in Flea’s

garage to jam on ideas before hitting the studio to record. Which says that there’s a magic surrounding that space, something inherently familiar to most of us that makes the garage a special place for playing music. For those of you still bashing it out in your own garages, this catalog is for you—be sure to check out all the great gear inside as well as articles that will help you make the most of your garage jams!

### On the Cover:

## RYAN TEDDER

Our June catalog features OneRepublic’s Ryan Tedder, who’s branched out from his band to produce, write and record with numerous pop stars. Check out our feature on Ryan starting on page 24 to learn more about this outstanding talent.

# 24

## DEPARTMENTS | FEATURES

## FINANCING

THIS JUST IN	4
Gifts for Dads & Grads	2-3
Hands-On Review: Studio One Professional 2.5	16
Love Thy Neighbor	34
Share and Share Alike	48
Hands-On Review: DLM Series Powered Speakers	56
Recording	4, 9
Microphones	5, 40
Keyboards	27
Accessories	36, 46, 62
Live Sound	50, 65
DJ Gear & Lighting	66
Order Form	74
Guitars	75
Drums	78
Deal Center Spotlight	80

Note: Stratocaster®, Strat®, Telecaster®, Tele®, Precision Bass®, P Bass®, Jazz Bass®, J Bass®, and the unique headstock designs of these guitars are trademarks of Fender Musical Instruments Corporation (FMIC). All rights reserved. FMIC is neither affiliated with nor endorses any non-FMIC products. Sale prices expire 04/30/13 and special offers expire 04/30/13 unless otherwise specified.

### 12-MONTH NO INTEREST FINANCING\*



Get 6 Months for Orders \$149+ or 12 Months for Orders \$499+. Apply today and enjoy the benefits of the Musician's Friend Credit Card.

- It's fast, easy and secure
- Take advantage of special financing offers
- Once approved, you can begin shopping at [musiciansfriend.com](http://musiciansfriend.com) right away

No Interest if paid in full within 12 months on any purchase of \$499 or more. Interest will be charged to your account from the purchase date if the purchase balance is not paid in full within 12 months or if you make a late payment. Offer valid until 06/30/2013.

\*12 months offer available on approved purchases of qualifying merchandise of at least \$700 made on the Musician's Friend Credit Card issued by Capital One, N.A. Minimum Payments required. Standard APR 22.9%; Penalty APR 26.9%. Minimum Interest Charge \$2. Offer expires 06/30/13.

### AKAI PROFESSIONAL SynthStation49 Keyboard Controller with iPad Dock

An advanced, intuitive controller designed specifically for the iPad. With unparalleled music creation capabilities, including direct in-app MIDI recording from its 49 full-sized velocity-sensitive keys, 9 backlit MPC-style drum pads, and an array of transport buttons, its adjustable-angled iPad dock lets you easily position the screen. Other features include USB port, headphone out, pitch/modulation wheels, and a sustain pedal. iOS CoreMIDI compatible with dozens of music apps available, it can also be used as a traditional USB/MIDI controller.

H72090 [see web for price](#)



### DIGITECH iStomp Downloadable Stompbox

The stompbox you can change with your iPhone. Turn the iStomp into any pedal. Simply connect your iPhone to the iStomp and in about the same time it takes to download a song you can turn the iStomp in to any pedal from DigiTech's Stomp Shop App. The iStomp comes with DigiTech's Total Recall digital delay and tube overdrive to get you started. Like traditional stompboxes, just step on the foot-switch to turn the effect on and off and adjust knobs to dial in sound.

H79958 MSRP \$229.95 **\$149<sup>99</sup>**



### APOGEE MiC USB

World-class Apogee recording on your iOS device. A super-compact, studio-quality USB microphone for use with your iPad, iPhone or Mac. About the size of an iPhone, MiC makes it easy to capture your best take with incredible quality, anywhere your music takes you. PureDIGITAL technology delivers your source in true tone to your iPad, while the level control and easy-to-read status indicator keeps your signal honest.

H80579 **\$229<sup>00</sup>**



### NUMARK iDJ Pro Premium DJ controller powered by iPad.

Expands your iPad's touch interface, seamlessly integrating with Algoriddim's djay for iPad app to form a completely new DJ experience. Features a sleek, brushed aluminum casing and is equipped with all the professional controls you expect, plus some design features and capabilities that will inspire new surges of creativity.

H80558 MSRP \$699.00 **\$499<sup>00</sup>**

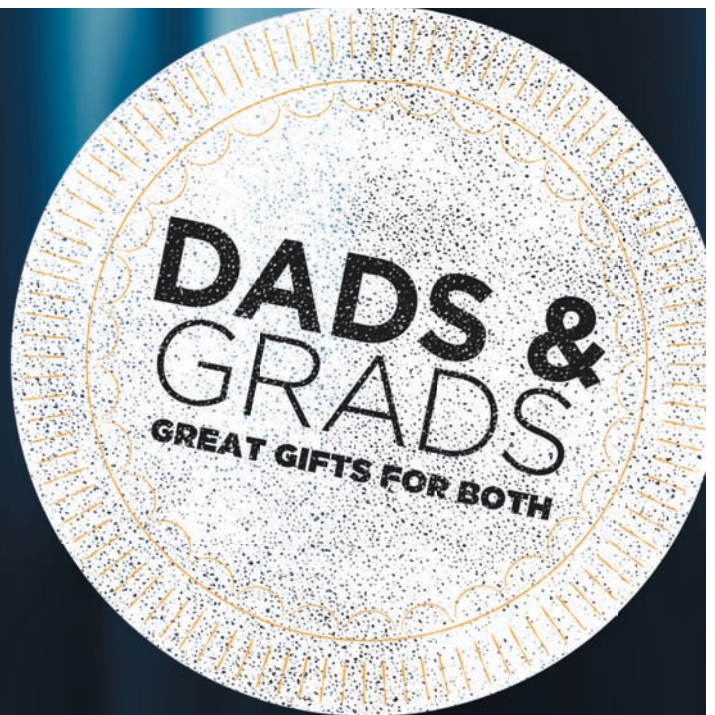

### MACKIE DL1608 iPad Mixer

Mix from anywhere in the venue. The DL1608 redefines live mixing by combining a full-featured digital mixer with the ease and mobility of the iPad. With 16 boutique-quality Onyx mic preamps, and 24-bit Cirrus Logic AD/DA converters, you're guaranteed professional quality sound. Seamless wired to wireless iPad control means you can mix from anywhere in the venue, and with support for up to 10 iPads, each band member can control their own monitor mix.

H80461 MSRP \$1,249.99 **\$999<sup>99</sup>**



### FOCUSRITE iTrack Solo

Mobile recording on a professional level. Introducing a professional approach to recording on your iPad. Featuring a renowned Focusrite microphone preamp and an input to simultaneously record guitar and vocals. iTrack Solo is the perfect companion for any singer-songwriter wanting to take their demos to the next level. With the very best in digital audio technology encased by a rugged aluminium unibody chassis, iTrack Solo will capture your sound with pristine quality.

H86942 MSRP \$199.99 **\$159<sup>99</sup>**

### IK MULTIMEDIA iRIG MIDI

MIDI power iOS. iRig MIDI is an ultra-compact standard Core MIDI interface for iOS that connects any MIDI-compatible device to the iPhone, iPod touch and iPad. Grab control of your favorite music apps with your MIDI keyboard, controller, pedalboard, and more, to add a hands-on feel to your music apps. Features include 3 MIDI ports, Micro USB port, dual LED's for MIDI activity, and two 5.2' MIDI cables. SampleTank and iRig MIDI Recorder music apps are also included.

H77704 **\$69<sup>99</sup>**





**MARTIN LXM Little Martin**

**Great for travelers and students.** Compact with rich tone, the LXM has a small, modified 0-14 body with a wood-patterned HPL top and Sitka spruce bracing, Micarta fingerboard and bridge, 23" scale, and modified low-oval neck with Martin's patented mortise. Gotoh tuners and the C.F. Martin script logo adorn the headstock. Choose black, natural or koa finish. Includes Martin gig bag.

515880 MSRP \$409.00 **\$289<sup>00</sup>**

**VOX AC30VR Valve Reactor Combo**

**A diverse soundscape of vintage and modern tones from a single amp.**

Using an old-school, split-panel design, it offers two distinct channels for impeccable cleans and two flavors of classic VOX overdrive. 2-band EQ on the Normal channel, with a 3-band EQ on the Overdrive channel for precise tone shaping. Tone Cut control dampens high-end frequencies. 30W through two 12" Celestion VX12 speakers, digital reverb, external speaker out and master volume control. Black.

584528 MSRP \$800.00 **\$549<sup>00</sup>**



**LINE 6 POD HD**

**The next-generation desktop recording solution for guitar has arrived!** The only desktop multi-effect to boast 16 state-of-the-art Line 6 HD amp models based on the most legendary classic and contemporary amps, 100+ modern and vintage-styled M-class effects, and a collection of essential digital and analog ins and outs. POD HD is the most up-to-date version of the original, time-tested lineage of Line 6 desktop direct-recording devices.



H72932 MSRP \$599.99 **\$399<sup>99</sup>**



**ZILDJIAN ZBT 3 Starter Set with Free 14" Crash** Intense ZBT sounds to start your set. 18" crash ride and a pair of 13" hi-hats plus a free 14" crash.

Sound grooves and round hammer strikes contribute to the sharp, focused sound.

502018 MSRP \$462.00 **\$199<sup>95</sup>**

**Hohner Case of Special 20s Harmonica 5-Pack** A special case at a special price.

It consists of 5 Special 20 harmonicas in the most popular keys: G, A, C, D, and E. These harps are known for their awesome response, superior bendability and sweet tone. To keep them safe while you travel, they come in a padded case with a plush black interior that can hold a total of 7 harps.

500325 MSRP \$250.00 **\$150<sup>00</sup>**



**MARSHALL Compact Refrigerator** A place to stack refreshments.

With control knobs that go to 11, authentic black fret cloth and the iconic Marshall logo across the middle, this heavy-metal fridge offers 4 cu. ft. of refrigerator space and .4 cu. ft. freezer compartment (adjustable from 0 to -6 degrees) for your heavy metal ice cubes.

H93936 MSRP \$640.00 **\$399<sup>99</sup>**

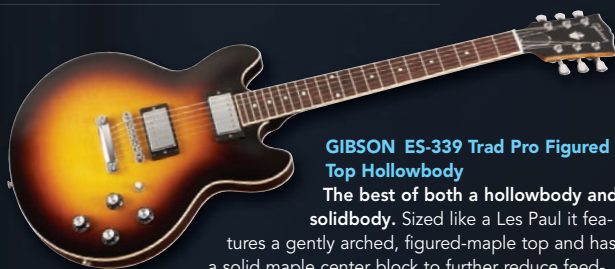

**GIBSON ES-339 Trad Pro Figured Top Hollowbody**

**The best of both a hollowbody and solidbody.** Sized like a Les Paul it features a gently arched, figured-maple top and has a solid maple center block to further reduce feedback and enhance sustain. Classic '57 neck and Super

'57 bridge pickups are wired to push/push volume pots that enable coil-splits in addition to a 10dB user-adjustable boost.

H92569 MSRP \$3,056.00 **\$1999<sup>00</sup>**

**LUDWIG Black Beauty Snare with Supra-Phonic Snares**

**One of the most desirable drums ever made.** An anodized, one-piece brass beaded shell produces a classic metallic-yet-warm sound and ease of tuning that this classic drum is famous for. Supra-Phonic snares and classic P-85 snare throw-off provide unmatched sensitivity.

446281 MSRP \$893.00 **\$580<sup>45</sup>**



# THIS JUST IN



## TC-HELICON VOICELIVE PLAY GTX GUITAR/ VOCAL HARMONY AND EFFECTS PEDAL WITH SENNHEISER e 835 fx MICROPHONE

This is the singing guitarist's dream machine with complete vocal and guitar processing. Features automatic backing harmonies, vocal double tracking, pristine EQ and compression and more.

H92540 MSRP \$612.00 **\$439<sup>99</sup>**



## EPIPHONE LIMITED EDITION LES PAUL CUSTOM PRO

Upgraded in a limited edition TV Silver. This "tuxedo" Les Paul features a mahogany body with a carved top and set-in mahogany neck. Chrome appointments, fully bound body, neck and headstock, and mother-of-pearl inlays give it a "dressed-to-kill" appearance. Comes with ProBucker-2 and ProBucker-3 pickups as well as tune-o-matic bridge.

H79044 MSRP \$915.00 **\$549<sup>00</sup>**



## PROPELLERHEAD REASON 7

The latest from one of the greatest. Reason 7 is here. The latest incarnation of one of the world's favorite music software packages brings a wide variety of enhancements to help you create more and better music. From start to finish, its ever-expandable, freely routable rack of instruments, effects and sounds has everything you need to write, record, remix and produce great-sounding tracks.

H95539 MSRP \$449.00 **\$399<sup>00</sup>**

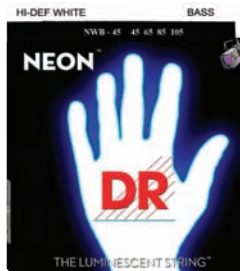

## DR STRINGS HI-DEF NEON WHITE COATED MEDIUM 4-STRING BASS STRINGS

Built to last. Made to glow. In natural light and stage light these strings sparkle brightly. Under ultraviolet black light, they appear to glow. Made from nickel-plated steel, these super bright colors are designed to sound clear, bright and musical.

H94794 **\$29<sup>99</sup>**



## MACKIE DL806 8-CHANNEL DIGITAL LIVE SOUND MIXER WITH IPAD CONTROL

8-channel digital mixer with wireless iPad control.

Mackie helped revolutionize the world of digital mixing with the DL1608. Now they've scaled things down to bring you the same incredible wireless freedom, but in a more manageable, compact size. The DL806 is an 8-channel version of its bigger brother, but has the same revolutionary wireless iPad control making any live sound engineer's workflow enjoyable.

H92680 MSRP \$999.99 **\$799<sup>99</sup>**

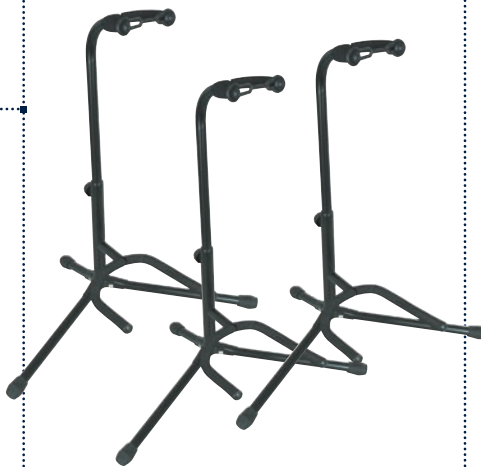

## MUSICIAN'S GEAR TUBULAR GUITAR STAND BLACK 3-PACK

Sturdy tubular folding stands at a price perfect for schools. These are covered in soft black neoprene rubber tubing to protect your guitars in between uses. Each folds up for easy transport. Note: they are not for nitrocellulose-finish guitars.

H95527 **\$20<sup>99</sup>**



## PDP CONCEPT PEDAL

A re-imagined line of PDP accessories. The flagship pedal of the PDP line is fast, smooth and unlike any PDP pedal before it. With an extended length brushed aluminum footboard, DW-style spring rocker adjustment and low-mass cam, it's a performer that rivals more expensive offerings.

H96669 MSRP \$163.99 **\$89<sup>99</sup>**



## CUSTOM BUNDLES FOR RECORDING AT HOME OR ON-THE-GO.

The recording process can at times seem extremely complex and intimidating, but the truth is it can often be simplified so even novice engineers can track like a pro. It used to be that if you wanted to record an album, song, or even just cut a demo, you had to spend a lot of time and money in a professional recording studio, but today there's an abundance of affordable recording solutions that make it easy for anyone to record songs in their own home. Our experts have pieced together some incredible recording packages with the essential ingredients you need to successfully record in your home, all at prices you won't find anywhere else. Here are just a few examples of packages we've put together for you.

Visit us online to see more recording bundles at:

[MUSICIANSFRIEND.COM/RECORDING-PACKS](http://MUSICIANSFRIEND.COM/RECORDING-PACKS)

## CUSTOM RECORDING BUNDLES



### PRESONUS AUDIOBOX COMPLETE DESKTOP RECORDING BUNDLE

This is an ideal package for singers and songwriters recording at home. Featuring a studio mic, headphones, cables, software, and a recording interface with just enough inputs to track up to two sources at the same time.

- PreSonus AudioBox Studio Recording Bundle
- Fostex PM0.3 3" Studio Monitors (Pair)
- Tripod Mic Stand with Fixed Boom
- RCA-1/4" Dual Patch Cable
- PreSonus Studio One Producer Software
- 6" Pop Filter

H97041 MSRP \$805.91

**\$499<sup>99</sup>**



### TASCAM US-1800 COMPLETE DESKTOP RECORDING BUNDLE

This bundle is designed for anyone who wants to record drums and multiple sources. With a 16-input interface, a pair of studio monitors, dual condenser mics, headphones, and required accessories, it's the perfect project studio start-up.

- Tascam US-1800 USB 2.0 Audio/Midi Interface
- M-Audio BX5 D2 Studio Monitors
- Sterling Audio SP50/30 Studio Condenser Microphone Pack
- XLR 20' Microphone Cable
- 6" Pop Filter
- TRS-TRS Balanced Patch Cable
- Tripod Mic Stand With Boom
- Gear One G900DX Headphones
- Cubase LE5 Software

H97042 MSRP \$1211.91

**\$799<sup>99</sup>**



### FOCUSRITE SAFFIRE PRO 40 COMPLETE DESKTOP RECORDING BUNDLE

Sound quality is a discerning factor when choosing recording gear, and Focusrite has some of the best sounding preamps available to consumers. Add in studio monitors, headphones, studio-grade condenser mics, and high-quality accessories and you're ready for pro-level recording.

- Focusrite Saffire Pro 40 FireWire Interface
- Yamaha H55 Studio Monitors
- Sterling Audio ST55 / ST31 Condenser Mic Package
- Tripod Mic Stand With Boom
- Monster 100 15' XLR Microphone Cable
- TRS-TRS Balanced Patch Cable
- ATH-M30 Professional Monitor Headphones

H97043 MSRP \$2146.81

**\$999<sup>99</sup>**

HAVE A QUESTION ABOUT RECORDING EQUIPMENT? CONTACT OUR EXPERTS: 888.410.7558

 audio-technica®



**A AT5040**  
H92820 **\$2999<sup>00</sup>**



**B C451**  
**65th Anniversary Edition**  
H92811 MSRP \$649.00  
**\$499<sup>00</sup>**



**C Baby Bottle**  
279003 **\$399<sup>00</sup>**

**A. AT5040**

**Exceptionally detailed studio condenser.**

Designed as a first-choice vocal microphone, the AT5040 features an extremely smooth top end with controlled sibilance. Large-diaphragm characteristics and fast transient response also make it ideal for recording acoustic instruments such as piano, guitar, strings and saxophone. The AT5040 represents a milestone in condenser design.

**B. C451 65TH ANNIVERSARY EDITION**

**Limited-edition small-diaphragm condenser with a legendary sound.**

AKG is celebrating 65 years of excellence with the C451 65th Anniversary Edition condenser microphone. The C451 Anniversary Edition embodies sound from the C451 EB with the CK1 capsule, delivering stunning quality and precision. It combines attractive design and high-quality "TITAN-Look" finish with stunning sound quality.

**C. BABY BOTTLE**

**Stellar performance in the studio.** Handcrafted solid state, Class A, discrete condenser mic with a precision-machined, gold-sputtered capsule enclosed in a lollipop spherical grille. Fixed cardioid pattern. Ideal for recording vocals, percussion, or any acoustical instruments. 20Hz-20kHz. 133dB max SPL.

**D. MA-201FET**

**A large-diaphragm condenser with classic Royer performance.**

The MA-201 has roots going back to when David Royer built custom mics for top studios. Featuring Jensen transformers, mil-spec FETs, and an ultra-clean signal path, it gives you a full-bodied sound reminiscent of the best-loved classic condensers. Great for vocals, acoustic instruments, overheads, and high-SPL sources.

**E. MA-301FET**

**Large-diaphragm multi-pattern condenser mic.**

The MA-301fet is a solid state condenser microphone. Based upon the popular MA-201fet designed by David Royer, the MA-301fet adds a 3-position pickup pattern selector, a 15dB pad and a switchable bass roll-off. Each MA-301fet microphone is carefully tested and evaluated, then packaged in its protective case with a professional grade shock mount.



**D MA-201 FET**  
581138 **\$695<sup>00</sup>**



**E MA-301 FET**  
H82157 **\$895<sup>00</sup>**



**F TLM-103 - Black**  
271397 **\$1099<sup>95</sup>**

**TLM-103 - Nickel**  
Same as 271397 with satin nickel exterior.  
271399 **\$1099<sup>95</sup>**





**\$100 INSTANT REBATE**

**MXL 890**

**Capture your vocal nuances.** Perfect for critical recording applications when the vocals need to be out front in the mix, it has transparent low-noise circuitry to deliver rich detail and an airy presence for smooth, natural-sounding vocals. Also well-suited for use as a room mic to capture the ambiance of performances.

H87204 MSRP \$399.99 **\$299<sup>99</sup>** Before Rebate **\$199<sup>99</sup>** After Rebate



**\$50 INSTANT REBATE**

**MXL 860**

**Side-address ribbon mic for instruments.** The MXL 860 is compact and versatile, making it ideal for many recording applications. The distinctive MXL 860 Ribbon has a durable cast metal body that makes it an excellent utility mic that can be positioned virtually anywhere in a studio. The 860 XL excels on electric guitars and horns.

H87205 MSRP \$259.99 **\$199<sup>99</sup>** Before Rebate **\$149<sup>99</sup>** After Rebate



**\$50 INSTANT REBATE**

**MXL 870**

**Versatile studio microphone.** The MXL 870 is a multi-purpose cardioid studio condenser mic with a wide diaphragm. It is a side-address microphone in the style of the great classic studio mics, and is especially great for vocals, and a wide range of other instruments.

H87200 MSRP \$259.99 **\$199<sup>99</sup>** Before Rebate **\$149<sup>99</sup>** After Rebate



**\$30 INSTANT REBATE**

**MXL 990/991 Recording Package**

**Your one-stop mic kit for vocals, drum overheads, acoustic guitars, and more.** The 990 has a silky, sweet high end and a tight, solid bass that's perfect for vocals. The 991 is a superior instrument mic that captures acoustic guitar and makes a great drum overhead. Both have gold-splattered diaphragms for a professional sound.

273166 MSRP \$299.95 **\$99<sup>99</sup>** Before Rebate **\$69<sup>99</sup>** After Rebate



**MXL V63M**

**World-class large-diaphragm sound at a rock bottom price.** An exclusive! Its 1"-diameter, 6-micron-thick diaphragm delivers high sensitivity and detailed recordings. Uses Mogami wire for added clarity. Balanced, low-noise output. Heavy-duty brass enclosure. 30Hz-20kHz frequency response. Cardioid pickup pattern.

273157 MSRP \$249.99 **\$199<sup>99</sup>**



For full selection, visit [musiciansfriend.com/lewitt](http://musiciansfriend.com/lewitt)

**NEW AT MUSICIAN'S FRIEND!**

**LCT AUTHENTICA SERIES**

The LCT Authentica Series from LEWITT introduces a new generation of highly versatile wired condenser microphones that all aim for setting new benchmarks of technology, sound quality and user-friendliness in both professional studio recording and onstage use. LCT Series combine innovative features to ensure error-free sonic perfection and peerless ease of use for today's demanding recording artists and engineers.



**LEWITT LCT 140**  
Pencil condenser perfectly suited for a wide range of sources.  
H95885 MSRP \$319.00  
**\$249<sup>00</sup>**

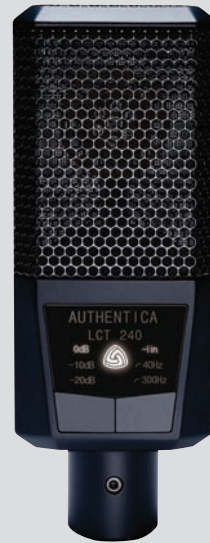

**LEWITT LCT 240**  
2/3-inch diaphragm, great for live and home studio.  
H95891 MSRP \$379.00  
**\$289<sup>00</sup>**



**LEWITT LCT 540**  
Multipurpose condenser ideal for vocals and acoustic sources.  
H95890 MSRP \$799.00  
**\$599<sup>00</sup>**



**LEWITT LCT 640**  
Large-diaphragm FET great for vocals and other sources.  
H95888 MSRP \$1079.00  
**\$799<sup>00</sup>**



**LEWITT LCT 940**  
Reference class tube/FET, excels on lead & background vocals.  
H95901 MSRP \$2150.00  
**\$1599<sup>00</sup>**



**DTP PERCUSSION SERIES**

With its DTP series, LEWITT introduces a complete family of cutting-edge, high-performance wired dynamic microphones designed specifically for drums, percussion and bass instruments. These high-quality mics stand out thanks to their sonic accuracy on stage as well as in studio settings. Uniform cardioids and super-cardioid patterns allow for high gain before feedback and a hardened steel mesh grille effectively resists wear.



**LEWITT DTP 340 TT**  
Dynamic mic for toms & snares  
H95900 MSRP \$119.00  
**\$89<sup>00</sup>**



**LEWITT DTP 340 REX**  
Dynamic kick drum mic  
H95881 MSRP \$239.00  
**\$179<sup>00</sup>**

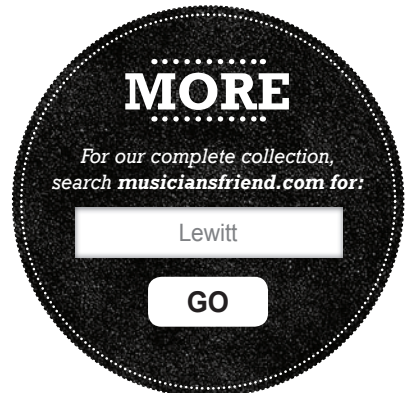

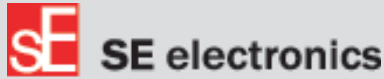

**A X1 Studio Bundle**  
H92116 MSRP \$349.00 **\$319<sup>00</sup>**

**A. X1 STUDIO BUNDLE**

**Studio mic and filter pack.** This studio bundle from sE pairs up the detailed X1 condenser with the Reflexion Filter X mic isolator. Get a crisp, clean source recording from the hand-built capsule of the X1, while virtually eliminating any room coloration of your sound with the RF-X mic filter. A perfect combo for recording in less than perfect environments.

**B. MK 4 STUDIO CONDENSER**

**Affordable, studio-quality condenser.** The MK 4 is a large-diaphragm, true condenser microphone designed for professional studio recordings. Featuring fine resolution and outstanding sound quality, it offers excellent value for the price, making it an ideal choice for project studios.

**C. C 214 LARGE DIAPHRAGM CONDENSER MIC**

**Affordable condenser, with acclaimed features.** In the history of recording, only a handful of mics have made the engineers must-have list. One is the AKG C 414. While not terribly expensive, it's still out of reach for many project studio owners. Enter, the affordable C 214, a cardioid condenser that combines one side of the legendary C 414 dual-capsule system and AKG's patented back-plate technology for a sound very close to the famous C 414. It handles everything from electric guitar to voice and orchestral instruments and features a 20dB pad and low-cut switch. Carrying case, windscreens, and spider suspension mount included.

**D. C 414 XLS CONDENSER MIC**

**A stage and studio staple redefined.** The C 414 XLS' predecessor, AKG's legendary C 414, needs no introduction. It is an audio tool found in most recording studios and has been used on thousands of hit records. It has been on stage with artists of every musical genre and is also used by leading broadcast facilities the world over. This new version of it offers 9 pickup patterns for you to choose the perfect setting for every application.

**E. BLUEBIRD MIC & DT770 HEADPHONE PACK**

**Record crystal-clear, soaring vocals without headphone bleed.** Like its namesake, the Bluebird really sings. This multi-purpose condenser mic is great for vocals, guitars, and close-miking drums and acoustic instruments. A perfect match for Blue's high-quality sound, DT770 headphones are like strapping a pair of expensive studio monitors around your head. Their closed design virtually eliminates headphone bleed into the mic.

**F. ST55 / ST31 CONDENSER MIC PACKAGE**

**High-quality instrument and vocal recording made affordable.** The Sterling Audio ST55/ST31 condenser mic package gives you an affordable means to record instruments and vocals with high-quality sound. It includes the Sterling Audio ST55 FET large-diaphragm and ST31 mid-size diaphragm condenser mics. The ST31 is a "pencil" condenser that is ideal for acoustic guitar, and other signals with sparkle, whereas the ST55 is a fine mic for vocals, bass drum and other broader response signals. Package also includes the PF2 Mesh Pop Filter and the SM4 shock mount.



**BUY BOTH & SAVE \$50**  
purchase H70286 and H71114 together and save \$50 instantly

**B MK 4 Studio Condenser**  
H70286 **\$299<sup>95</sup>**  
**MKS 4 Shockmount for MK 4**  
H71114 **\$99<sup>95</sup>**



**C C 214 Large Diaphragm Condenser Mic**  
271335 MSRP \$469.00  
**\$399<sup>00</sup>**



**D C 414 XLS Condenser Mic**  
485812 MSRP \$1549.00  
**\$1049<sup>99</sup>**



**E Bluebird Mic & DT770 Headphone Pack**  
270378 MSRP \$948.99  
**\$499<sup>99</sup>**



**F ST55 / ST31 Condenser Mic Package**  
486264 MSRP \$739.96  
**\$199<sup>99</sup>**



### MiC USB MIC

World-class Apogee recording on your iOS device. A super-compact, studio quality USB microphone for use with your iPad, iPhone or Mac. About the size of an iPhone, MiC makes it easy to capture your best take with incredible quality, anywhere your music takes you. PureDIGITAL technology delivers your source in true tone to your iPad, while the level control and easy-to-read status indicator keeps your signal honest.

H80579 **\$229<sup>99</sup>**



### Spark Digital

Solid state condenser with USB connectivity. Spark is a cardioid, solid state condenser microphone designed to help you achieve professional quality recordings in any creative environment. Features a custom-designed condenser capsule with Class-A discrete electronics resulting in superbly detailed and uncolored output, making it the ideal microphone for recording vocals, drums, guitars, pianos, brass, woodwinds, and just about anything else you can imagine.

H87350 **\$199<sup>99</sup>**

## SAMSON®

### Meteor USB

Futuristic USB mic for your laptop or iPad. The Meteor Mic is the universal solution for inputting live audio to your computer. It's perfect for home studio applications, but the Meteor Mic is also ideal for Skype, iChat or voice recognition software. Its cardioid pickup pattern, smooth frequency response and 16-bit, 44.1/48kHz resolution give you professional audio results everytime.

H81415 MSRP \$112.49 **\$69<sup>99</sup>**



iPad sold separately

## CASTIV™

### Guitar Sidekick

Keep your tabs in view with this smartphone guitar clip. The Guitar Sidekick is designed to easily clip your smartphone or any similar device to your guitar. Resting just below the nut on your guitar's headstock, the Sidekick positions your device in perfect view for easy access to your favorite guitar apps.

H91060 MSRP \$29.99 **\$19<sup>99</sup>**



### iKlip

Universal mic stand adapter for iPad and iPad 2.

Cutting-edge, durable thermoplastic mic stand adapter with sure-grip touch points holds your iPad or iPad 2 securely to any mic stand. Multi-angle adjustable design makes for optimal viewing and accessibility with all buttons and connection ports free from obstruction.

Lets you share music app creations or read lyrics in live or studio settings. H75739 **\$39<sup>99</sup>**



### Smart Station

Attaches your smartphone to any standard mic stand. The Smart Station is a microphone stand adapter designed to hold Smartphones like the iPhone. Simply attach your device to the adapter and mic stand of your choice and you can have the power of your apps and devices like metronomes and tuners right at your fingertips.

H91059 MSRP \$39.99 **\$24<sup>99</sup>**



### iRig MIC Cast

Ultra-compact voice recording microphone for iPhone/iPod touch/iPad, perfect for interviews and voice memos. Ultra-compact, portable voice recording microphone designed specifically for recording podcasts, interviews, voice memos and more. Provides a pocket-sized voice recording solution with crystal-clear audio quality, and a tight unidirectional pickup pattern that minimizes background noise, making it ideal for single-source audio recording. Like other IK Multimedia microphones, the iRig Mic Cast includes the iRig Recorder and Vocalive apps for free.

H81193 **\$39<sup>99</sup>**

iPhone sold separately



### Tab Station

Attaches your iPad or similar tablet to any standard mic stand. The Tab Station is a microphone stand adapter designed to hold onto a tablet computer like the iPad, and keep it within easy reach during your practice or performance. The unique design is extremely flexible for the most optimal viewing positions.

H91061 MSRP \$44.99 **\$29<sup>99</sup>**



### iKlip Studio

Dependable, shock-resistant studio desktop stand for iPad. The iKlip Studio is the ultimate desktop iPad stand designed for musicians. Made of a lightweight, shock-resistant thermoplastic that will securely hold your iPad without any scratching. Secure rubber foot pads prevent unwanted sliding while in use, and the flexible orientation design allows for angled positioning, and can be easily rotated horizontally or vertically.

H81192 **\$29<sup>99</sup>**



### iKlip MINI

Universal microphone stand adapter for iPhone and iPod touch. iKlip MINI is a universal microphone stand adapter for the iPhone and iPod touch to support your iOS device on stage or in the studio. Made of sturdy, durable thermoplastic, iKlip MINI is compatible with every existing iPhone and iPod touch, and comes with a detachable bracket support for the iRig guitar interface.

H77514 **\$39<sup>99</sup>**



### FITFOLIO

Protect your new iPad 3 or iPad 4 in tailored style with the fashion-friendly FitFolio. This sleek form-fitting case features a protective padded cover, soft microsuede interior, and a custom hardshell cradle. A new snap closure keeps your iPad case securely shut, while integrated magnets enable your iPad's sleep/wake function.

### FitFolio for iPad

Choose from Black Vegan Leather, MegaPlaid Black or Harbor Blue H94494 **\$39<sup>95</sup>**



iPad Sold separately

While supplies last



H81554

**\$100 PRICE DROP**



H81551

H82609

**A Mbox 3 Mini and Pro Tools Express**

Compact 2x2 audio interface.

H81554 MSRP \$299.00

~~\$299.00~~ **\$199<sup>00</sup>**

**Mbox 3 and Pro Tools Express**

Portable 4x4 audio interface.

H81551 MSRP \$499.00 **\$499<sup>00</sup>**

**Pro Tools + Mbox Pro (3rd Gen)**

High-resolution 8x8 audio interface.

H82609 MSRP \$1099.00 **\$999<sup>00</sup>**

**Focusrite®**



H77928



H92685

**D Scarlett 2i2 USB Audio Interface**

2 inputs and 2 outputs.

H77928 MSRP \$189.99 **\$149<sup>99</sup>**

**Scarlett Studio**

Scarlett 2i2, CM25 condenser mic, HP60 reference headphones, and cables.

H92685 MSRP \$299.99 **\$249<sup>99</sup>**



**F Liquid Saffire 56**

581707 MSRP \$1299.99

**\$999<sup>99</sup>**

**G Forte USB Audio Interface**

H88541 MSRP \$749.99 **\$499<sup>99</sup>**



**NI NATIVE INSTRUMENTS**



**\$30 INSTANT REBATE**

**B Complete Audio 6**

H74207 MSRP \$249.00

**see web for price**

**steinberg Creativity First**



**\$20 INSTANT REBATE**

**C UR22**

H92246 MSRP \$199.99

**see web for price**

**UA UNIVERSAL AUDIO**



**E Apollo Duo-Core**

H80029 MSRP \$2499.00 **\$1999<sup>00</sup>**

**Apollo Quad-Core**

H80030 MSRP \$2999.00 **\$2499<sup>00</sup>**

**Apollo Thunderbolt Option Card for Apollo Audio Interface**

H90348 MSRP \$599.00 **\$499<sup>00</sup>**

**A. MBOX SERIES**

**Work how you want—and sound amazing.** The Mbox family brings the professional quality of Avid's recording systems into your personal home studio. Each interface offers premium sound, performance, and portability. Choose the Mbox + Pro Tools bundle to create music with an industry-standard DAW, or maybe an Mbox or Mbox Mini with Pro Tools Express software to elevate your recordings.

**B. COMPLETE AUDIO 6**

**6-Channel premium audio interface.** Complete Audio 6 is a premium-quality, 6-channel audio interface that provides everything you need to record, play and perform music, with four balanced analog ins/outs, digital stereo out, MIDI and low-latency performance—all in a sleek, rugged metal casing.

**C. UR22**

**USB 2.0 desktop recording interface, with MIDI I/O.** From the minds behind Cubase, the latest addition to Steinberg's UR series of recording interfaces, the UR22, brings a legacy of superb sound, ease of use, and audio expertise to your desktop. With custom Yamaha DSP and seamless integration with Cubase, the UR22 will be the hub of your home studio.

**D. SCARLETT SERIES**

**Capture every note and subtle detail with great clarity.** The Scarlett Series from Focusrite offers a variety of USB powered audio interfaces capable of handling any scenario you may encounter. From the ultra-compact Scarlett 2i2 to the input loaded Scarlett 18i6, all interfaces in this series feature Focusrite mic pres and professional quality audio conversion. Pick the size that fits you best.

**E. APOLLO SERIES**

**High-resolution recording, with a classic analog sound.** The Apollo is an 18x24 FireWire/Thunderbolt-ready audio interface that delivers the feel of analog recording. This professional interface combines genuine UA design with class-leading 24-bit/192kHz sound quality and onboard Realtime UAD Processing.

**F. LIQUID SAFFIRE 56**

**Famed Liquid technology and flexible routing.** With a sonic legacy passed down from the million-dollar Forte console, Focusrite has made an extremely powerful and versatile 24-bit/192kHz audio interface for the modern age. In addition to 6 analog mic pres, 2 Liquid preamps provide 10 emulations based on revered preamps such as the Neve 1073, Pultec MB-1, and Telefunken V72. Get the full story at our website.

**G. FORTE USB AUDIO INTERFACE**

**Premium 2-in, 4-out portable USB interface.** The Forte is a portable, professional USB audio interface with 2 ins and 4 outs, housed in a compact, sturdy aluminum case. Incorporating high-quality precision 24-bit AD/DA converters, the Forte operates at sample rates up to 192kHz, with a color OLED display to indicate levels, and a breakout cable for XLR and TRS inputs, and an easy connection to both Mac and Windows computers via USB 2.0.

**PreSonus**



**A StudioLive 16.0.2**

H73218 **see web for price**  
**StudioLive 16.4.2**  
 478507 **see web for price**  
**StudioLive 24.4.2**  
 485770 **see web for price**



**B AudioBox USB**

243007 MSRP \$179.95 **\$149<sup>95</sup>**  
**AudioBox Studio Recording Bundle**  
 H76028 MSRP \$299.95 **\$249<sup>95</sup>**  
**AudioBox USB Recording Package**  
 243008 MSRP \$722.86 **\$349<sup>99</sup>**



**C M-Track**

H95760 MSRP \$149.95 **\$99<sup>99</sup>**  
**M-Track Plus**  
 With digital I/O and Pro Tools Express.  
 H95761 MSRP \$199.95 **\$149<sup>99</sup>**



H95791

**D US-322**

2x2 interface with DSP mixer.  
 H95791 MSRP \$239.99 **\$149<sup>99</sup>**

**TASCAM**



H65527

**US-1800**

16x4 interface with MIDI I/O.  
 H65527 MSRP \$399.99 **\$299<sup>99</sup>**

**Focusrite**



**E iTrack Solo**

H86942 MSRP \$199.99 **\$159<sup>99</sup>**



**F JAM**

H72946 **\$129<sup>00</sup>**

**G ONE**

H92756 **\$349<sup>00</sup>**



**H Duet 2**

H92851 **\$649<sup>00</sup>**



**I Quartet**

H89223 **\$1395<sup>00</sup>**

**A. STUDIO LIVE SERIES**

The StudioLive Series Mixers incorporate all the important aspects of analog hardware mixers and seamlessly integrates them with the ease of digital mixing. With incredible signal-processing power, and a host of enhanced features like Smart frequency analysis, new EQ and talkback features, and extensive iPad control, these are more than just mixers.

**B. AUDIOBOX SERIES**

The PreSonus AudioBox series is a new generation of USB 2.0 audio/MIDI interfaces that take hardware and software integration to the logical next step. Combined with PreSonus Virtual StudioLive (VSL) software, they provide reverb, delay, and the same Fat Channel compression, limiting, semi-parametric EQ, and high-pass filter, as the PreSonus StudioLive 16.0.2 digital mixer – all with inaudible latency. With just an AudioBox running VSL and your computer, you can mix a studio session, live show, or power a DJ rig, all while monitoring and recording with or without realtime processing.

**C. M-TRACK SERIES**

The M-Track Series are the latest audio interfaces from M-Audio that open the door to computer-based music making. The M-Track and M-Track Plus both offer 2x2 recording capability with MIDI I/O, while the plus version adds in a rugged metal chassis and digital audio. All models in this series include a copy of Ignite music creation software, while M-Track Plus includes a copy of Pro Tools Express.

**D. US SERIES**

The Tascam US line of audio interfaces are made for professionals, and cover a wide variety of I/O options from the compact 2-input US-322 with on-board DSP mixer, to the high-resolution US-1800 that offers up to 16-inputs for tracking multiple sources at one time.

**E. iTRACK SOLO**

iTrack Solo is an Apple-certified "Made for iPad" device. Featuring 2 inputs with top digital audio technology, encased in a rugged aluminum chassis. It's perfect for mobile recording setups.

**F. JAM**

A pocket-sized interface at an unprecedented price, JAM brings the legendary sound quality of Apogee to iPad, iPhone and Mac. Use the multicolor status LED to easily monitor input levels, and experiment with amazing tones using the guitar amps and effects in compatible apps.

**G. ONE**

The Apogee ONE is designed for fast and easy recordings on your favorite iOS device or Mac, and it sounds amazing. Using Apogee's premium AD/DA conversion paired with its advanced built-in mic, ONE is capable of producing pristine quality audio for podcasts, voice-overs, or just about any music application.

**H. DUET 2**

Duet 2 makes it easier than ever to capture high-end recordings wherever your mobile rig takes you. With an award-winning audio interface, world-class preamps, headphone amp, MIDI interface, and legendary audio conversion, Duet 2 is everything you need to record on the road.

**I. QUARTET**

Quartet is a professional USB audio interface designed to deliver the ultimate desktop recording experience to the Mac-based studio. Featuring 4 ins and 8 outs of Apogee's AD/DA conversion technology as well as 4 world-class mic pres. Quartet bridges the gap from Duet to Ensemble.

# ZOOM



**A R8 Recorder/Sampler/USB Interface** H74535

MSRP \$524.99 **\$299<sup>99</sup>**

**R16 Multitrack Mobile Production Studio** H70249

MSRP \$699.99 **\$399<sup>99</sup>**

**R24 Music Production System** H70259

MSRP \$874.99 **\$499<sup>99</sup>**



**B Q2HD Handy Video Recorder** H85971

MSRP \$349.99 **\$199<sup>99</sup>**



**C H4n Handy Recorder** H70237

MSRP \$549.99 **\$269<sup>99</sup>**

## A. ZOOM PORTABLE RECORDERS

**Compact production powerhouses.** Zoom portable recorders seamlessly combine multi-track recording with intuitive control and features that make them ideal both in the studio and in the field. Capture audio from any setting, from live performances to audio for film, and instantly plug in to your DAW with the built-in interface and controller features. The R8 and R24 also give you sampler features.

## B. Q2HD HANDY VIDEO RECORDER

**HD video and pro audio in a handheld device.** Record recitals, music or dance lessons, lectures or anything else you want to preserve for sharing or for your own future reference. It streams live in real time, records in 1080p HD resolution, 24-bit/96kHz PCM sound quality, and has zoom and lighting adjustment functions that will help your videos look their best.

## C. H4N HANDY RECORDER

**Capture perfect stereo images from the palm of your hand.** The H4n is one of Zoom's most sophisticated pocket recorders, featuring a digitally controlled mic pre with 24-bit/96kHz linear PCM and MP3 recording. The XY stereo condenser mics provide perfect localization for stereo recording, along with Hi-Z instrument inputs, studio effects, tuner, USB 2.0 port, metronome, and more.

## D. LS SERIES RECORDERS

**Elite class of handheld recorders.** Olympus Digital Linear PCM Recorders provide better-than-CD-quality sound, multiple recording formats, and plenty of internal memory as well as removable SD media. High-sensitivity microphones capture every detail and nuance of a recording. The durable, lightweight aluminum body allows for one-handed use.

## E. PCM-M10

**Pint-sized companion for composing, recording, and playback.** The PCM-M10 includes high-resolution 24-bit/96kHz recording, 4GB flash memory, a pair of stereo condensers, pitch control, limiter, low-cut filter, track marking, record buffer, and more, all tucked into a stylish and rugged design.

## F. DR-05

**CD-quality recording in the palm of your hand.** Record super-clean 24-bit/96kHz audio to microSD/SDHC media thanks to the DR-05's specially designed low-noise circuitry and improved stereo mics that handle up to 125dB SPL. Peak Reduction automatically sets recording gain, while limiter and low-cut filter ensure distortion-free capture.

## G. DR-07MKII

**A simple, compact way to record high-quality sound.** The DR-07 MKII is a portable digital recorder with style. The pair of built-in mics captures a wide stereo image, recording in either MP3 or 16/24-bit WAV format. AA batteries power the DR-07 and it transfers files via USB 2.0 connection. Includes a windscreens, tripod stand mount and 2GB SD card to start recording right away.

## H. DP-24 24-TRACK DIGITAL PORTASTUDIO

**Compact, CD-quality recording in a portable, digital studio.** This mobile 24-track studio features solid state recording, color LCD display, channel strip controls, 18 linear channel faders, master fader, and channel strip encoders with controls for EQ, pan and FX. You can easily achieve quality recordings anywhere you need to, and, with its built-in CD-RW drive you also have instant mixdown and back-up options.

# OLYMPUS

**D LS-12 Linear** H91548

Built-in 2GB Flash Memory.

MSRP \$199.00

**\$149<sup>99</sup>**

**LS-14** H91547

Built-in 4GB Flash Memory.

MSRP \$249.00

**\$199<sup>99</sup>**



# SONY

**E PCM-M10** 484927

MSRP \$399.95

**\$299<sup>99</sup>**



**F DR-05** H72437 MSRP \$179.00 **\$99<sup>99</sup>**

# TASCAM

**MAIL-IN OFFER  
FREE HEADPHONES**  
with H72437 or H72438

**G DR-07MKII** H72438 MSRP \$279.99 **\$149<sup>99</sup>**



**FREE ST55/ST31 mic package & EXM cable**  
(\$773.95 MSRP) with H80452

**H DP-24 24-Track Digital Portastudio** H80452 MSRP \$899.00 **\$799<sup>99</sup>**

12 More models. More colors. More styles. Visit [musiciansfriend.com](http://musiciansfriend.com)



**RAINPAK AUDIO SERIES**

RainPAK is a complete hardware and software solution designed to help you get into the creative zone fast. Each RainPAK includes: Rain audio and video workstations, Creative software and hardware, the Rain Ensemble Plug & Play Service, and RainCare Tech Support & Warranty. Available in home, project, and pro configurations. See our web listing for details.

- RainPak Audio - Steinberg Home Studio  
H90397 MSRP \$1446.99 **\$1199<sup>99</sup>**
- RainPak Audio - Steinberg Project Studio  
H90398 MSRP \$2076.98 **\$1899<sup>99</sup>**
- RainPak Audio - Steinberg Pro Studio  
H90396 MSRP \$3326.97 **\$2999<sup>99</sup>**



- A** iMac 21.5-inch: 2.7GHz Quad-core Intel Core i5  
H92149 **\$1299<sup>00</sup>**
- iMac 21.5-inch: 2.9GHz Quad-core Intel Core i5  
H92147 **\$1499<sup>00</sup>**
- iMac 27-inch: 2.9GHz Quad-core Intel Core i5  
H92148 **\$1799<sup>00</sup>**

**A. iMac**

The new iMac; redefined, re-imagined, and re-engineered. Apple's best-selling desktop gets a refreshing new design and a host of upgrades that make it one of the most powerful, performance-enhanced desktop computers on the market. The redefined iMac packs all of its upgrades into a razor-thin, all-in-one design with a brilliant 21.5-inch or 27-inch widescreen display. Available with 2.7GHz or 2.9GHz configurations.



**B** iPod nano 16GB  
H91316 **\$149<sup>00</sup>**



**C** iPod classic 160GB  
583430 **\$249<sup>00</sup>**

**B. iPod nano 16GB**

Take your music, photos, and videos with you everywhere. Don't let its size fool you. The next-generation iPod nano has been completely reimagined, with an innovative thin body design that's about the size of a credit card, and loaded with features. With 16GB of space and 7 designer colors, there's an iPod nano that will fit your style. See our web listing for more detail.

**C. iPod classic 160GB**

The largest-capacity iPod is for more than just music and movies. Create the ultimate press kit with your music, photos, and videos, and carry it with you at all times – you never know who's going to show up at the gig. And with 160GB of storage, you can use it to transfer your DAW files from studio to studio. And while you're sitting in the studio lounge waiting to do your takes, you can still entertain yourself with music and videos.



**NEW**

**D** HP-P1 Portable Headphone Amp  
H95725 MSRP \$799.00 **\$649<sup>99</sup>**

**D. HP-P1 PORTABLE HEADPHONE AMP**

Headphone amp and DAC converter in one. The new Fostex HP-P1 is an innovative portable headphone amplifier with D/A converter that receives its audio signal digitally from iPod/iPhone 30-pin dock connector. Featuring an ultra-high quality 32-bit DAC and exclusively designed audiophile analog circuitry, the sonic performance and fidelity of the headphone signal has to be experienced to be believed.



NEW

### Eris E8

**High-definition 2-way 8" nearfield studio monitor.** When mixing music you want a pair of studio monitors that will accurately reveal the truth about what you're listening to, and the Eris series from PreSonus are designed to do just that. With its 8" Kevlar low-frequency transducer, the Eris E8 provides an extended low end all the way down to 35Hz, and with its extra juice it can deliver up to 105 dB SPL peak.



H93678 MSRP \$399.95 **\$249<sup>95</sup>ea**

### Eris E5

Same as H93678 with 5.25-inch Kevlar<sup>®</sup> low-frequency transducer.

H93713 MSRP \$199.95 **\$149<sup>95</sup>ea**



601417



601418

The Yamaha HS Series has the inherited universal mix-translation legacy and distinctive white cones of the industry-respected NS-10s, designed to deliver your mixes with transparent honesty. Room control and frequency response switches allow custom tailoring of the monitor's response to give you accurate performance in any environment.

**HS50M 5" Powered Studio Monitor**  
70W, 5" woofer and 3/4" tweeter.

601417 MSRP \$250.00 **\$149<sup>99</sup>**

**HS80M 8" Powered Studio Monitor**  
120W, 8" woofer and 1" tweeter.

601418 MSRP \$450.00 **\$249<sup>99</sup>**



KRK's Rokit G2 (Generation 2) powered studio monitors are designed to give amazing performance and accuracy. They have radically curved edges that virtually eliminate diffraction and provide a wider sweet spot. They also feature a great-looking cabinet, front-firing bass port, yellow glass-aramid composite woofer, and soft-domed tweeters. Dual high-power amplifiers and active crossovers provide a smooth reproduction. With the most accurate response curve in their class, Rokits ensure that you'll hear all of the details in your mix.

### Rokit 5 G2

With 5" woofer and 75W biamplification.

482825 MSRP \$299.00 **\$149<sup>50</sup>ea**

### Rokit 6 G2

With 6" woofer and 100W biamplification.

482826 MSRP \$399.00 **\$199<sup>50</sup>ea**

### Rokit 8 G2

With 8" woofer and 140W biamplification.

482827 MSRP \$499.00 **\$249<sup>50</sup>ea**



### MR5mk2

**Power, performance, and clarity for world-class mixes.** MR5mk2s are extremely balanced, with high-frequency clarity and midrange definition you can count on. These monitors are designed with a low-distortion 5.25" LF driver and high-output 1" soft dome tweeter, with precision amplification, 85W total system power, adjustable HF and LF acoustic controls, and flexible input connections.

H72050 MSRP \$199.99 **\$149<sup>99</sup>ea**

### MR8mk2

Same as H72050 with 8" LF driver and 150W power.

H72049 MSRP \$329.99 **\$249<sup>99</sup>ea**

BESTSELLER



### BX5 D2 Studio Monitors

**Provide a natural-sounding sweet spot.** With Kevlar 5" low-frequency drivers and waveguide-loaded 1" silk-dome tweeters, the biamplified, 70W BX5 D2 offers cohesive, accurate sound. Custom Class A/B amplifiers deliver superior dynamics and tonal accuracy across the frequency spectrum. Optimized rear ports offer extended LF response. Balanced XLR and 1/4" inputs.

H77461 MSRP \$399.00 **\$299<sup>00</sup>pr**

### BX8 D2 Studio Monitors

Same as H77461 with 130W power, 8" low-frequency drivers, and 1-1/4" high-frequency drivers.

H77460 MSRP \$599.00 **\$499<sup>00</sup>pr**



NEW



### PM0.3 3" Studio Monitors Grey

**3" Personal active speaker system.** The PM0.3 is Fostex's first two-way powered monitor speaker system. The combination of the dedicated 3" LF and 3/4" HF drivers together with the built-in D-class power amplifier delivers unparalleled audio performance in this class. The PM0.3, inheriting the familiar cosmetic design of the best selling PM-series, is ideal for space-limited desktop home studio, PC audio and MP3 reproduction

H95724 MSRP \$249.99 **\$129<sup>99</sup>pr**



**BUY 1 GET 1  
HALF OFF**

**A7X Powered Monitor**  
A new benchmark in near-field monitoring. Featuring a drastically improved version of ADAM's award-winning ribbon-tweeter and a 7" midwoofer, the 100W LF/50W HF A7X excels at nearfield monitoring. Additional controls include HF gain and 2 shelf filters (HF/LF). XLR (bal) and RCA (unbal) connectors.

H65551 see web for price

**ARTist 3 Powered Studio Monitor**  
The smallest big sound ever. The ADAM Audio ARTist 3 is their smallest and most compact powered monitor to date. The compact size of this monitor makes it perfectly suited for all environments where space is limited, but sound shouldn't be constricted. Countless studios around the globe are already using the X-ART technology in their ADAM monitors and treasure the precision and clarity these speakers offer.

H85321 MSRP \$400.00 **\$350<sup>00</sup>ea**



**F5 Near Field Monitor**  
5" Woofer, and 25mm voice coil  
H90330 **\$249<sup>99</sup>ea**

ADAM Audio monitors are found in top recording and post-production studios all over the world, and have taken their extensive knowledge of studio speaker technology and created a more affordable entry line of monitors. Each of the compact F Series monitors include enhanced designed X-ART tweeters, deep bass response midwoofers and adaptive environment controls.

**F7 Near Field Monitor**  
7" Woofer, and 37mm voice coil  
H90329 **\$399<sup>99</sup>ea**



**dynaudioacoustics®**

**BM5A MKII Studio Monitor**  
An established industry standard made louder, clearer, and more accurate than ever. Handcrafted drivers perfectly matched to custom dual 90W amps deliver 117dB SPL. Long-excursion 7" woofer maintains linearity for cleaner, tighter bass. 3 analog filters compensate for room acoustics and console reflections.

430563 MSRP \$625.00 **\$499<sup>00</sup>ea**

**DBM50 Active Studio Monitor**  
H87348 MSRP \$625.00 **\$499<sup>00</sup>ea**



**MACKIE®**

**Big Knob Studio Command System**  
Makes recording system setups way easier to use. Provides easy monitor and source switching, intuitive level control, and talkback. Its large knob allows precise level adjustments. The push of a button chooses among 3 pairs of studio monitors or among up to 4 stereo inputs, while sending custom headphone mixes to musicians and communicating with them via talkback. See our website for the full scoop.

700343 MSRP \$389.99 **\$299<sup>99</sup>**



**PreSonus**

**Monitor Station Studio Control Center**  
Console master section control for your DAW. While everybody was thrilled with what DAWs could do, PreSonus realized what they were missing – the monitoring and communications abilities of a console master section. To properly manage tracking and mixing, the Monitor Station provides talkback, speaker switching, and 4 ultraloud and clear headphone amplifiers with independent volume control and source selection – delivering everything you need to control your recording environment.

241727 MSRP \$369.95 **\$299<sup>95</sup>**



**UP TO \$75 MAIL-IN REBATES**

**dbx**  
by HARMAN

**266xs Compressor/Gate**  
Makes recording system setups way easier to use. Provides easy monitor and source switching, intuitive level control, and talkback. Its large knob allows precise level adjustments. The push of a button chooses among 3 pairs of studio monitors or among up to 4 stereo inputs, while sending custom headphone mixes to musicians and communicating with them via talkback. See our website for the full scoop.

H72801 MSRP \$209.95 **\$149<sup>95</sup> Before Rebate**



**166xs Dual Compressor Limiter**

Limit the chance of damage to expensive speakers. The dbx 166xs is an ideal solution for controlling unwanted spikes in volume during recording, or to maintain smooth consistent levels when mixing. Just like dbx's 266xs, the 166xs can operate in stereo or dual-mono modes, and features quality XLR/TRS inputs and outputs, but in addition, the dbx 166xs also features the PeakStop limiter, which provides an absolute ceiling for peak excursions or large transients that could otherwise cause damage to expensive speakers.

H72799 MSRP \$339.95 **\$239<sup>95</sup> Before Rebate**



**MAIL-IN OFFER**  
**FREE UAD2 Duo**  
(Your choice of PCIe or Satellite)  
with 250012



**UNIVERSAL AUDIO**



**LA-610 MkII**

Vintage channel strip with user-inspired features and groundbreaking price. Based on the 610 tube mic pre and EQ used to record mega stars from Frank Sinatra to Eddie Van Halen, the LA-610 MkII incorporates the legendary LA-2A-style opto-compressor. Then UA added true bypass, larger metering, improved output signal, and an auto-sensing power supply. Details at our website.

250012 MSRP \$1,999.00 **\$1599<sup>00</sup>**

# HANDS-ON REVIEW

## Studio One Professional Version 2.5

PreSonus continues to build on Studio One's promise, while retaining its original vision

By Craig Anderton, Editor in Chief, Harmony Central

In a little over four years, Studio One Professional (SOP for short) has gone from "who needs another DAW?" to being an accepted, well-respected mainstream DAW. Rather than dwell on details (you can download a trial version and explore it yourself), let's "zoom out" and analyze why SOP has managed to make these kind of inroads, and why not only have some people jettisoned their existing DAW for SOP, but also, why even some who've stayed with a different DAW have added SOP to their toolkit.

### More than Music Creation

PreSonus is into making tools "from riff to release," and SOP exemplifies that philosophy by emphasizing publishing your music after you've created it. There are two elements to this; the first is that SOP is really two programs in one—a multitrack recording DAW, and a complete mastering/authoring program for creating CDs or online collections of downloadable files. But SOP's genius aspect is how the two are integrated.

For example, suppose you've recorded ten songs, loaded them into the mastering (project) page, tweaked them for consistent levels and dynamics, and are about to upload your collection to SoundCloud or Nimbit (or burn a CD)—but the vocals are just a little low in cut 3. You don't have to quit the mastering page, call up the file, make the change, re-render, re-load into the mastering page, etc.; you can jump right back into the mix from the mastering page, do your edit, return to the mastering page, and tell it to update the mix. Done.

The second element is publishing. Whether you're burning one CD for a friend or exporting a DDP file to a professional duplicator, you can do it in SOP—as well as upload data-compressed (or non-compressed) files to the web. I've used SOP to send files to duplicators for several album projects, and all went without a hitch. Couple this with mastering-quality processors, along with a generous assortment of analysis tools, and it's no wonder that SOP gets the call when I need to master/prepare an album for publishing.

### A Question of Vision

As a multitrack DAW, SOP isn't physically that different from others—it has audio and MIDI tracks, hosts plug-ins, has comprehensive mixing options, does automation, and the like. But SOP's strength is that it focuses with laser precision on the music creation process (e.g., there's no notation or surround support). SOP received its initial warm reception because it was sleek, reliable, and fast; wisely, PreSonus has never lost sight of that vision, and avoided the temptation to keep adding features that served only a handful of users but added to bloat. Sure, they folded in Melodyne for quality pitch editing, and developed an amp sim, but many of the updates have been dedicated to streamlining the workflow and code even further. As an analogy, an SOP update is like sharpening a knife—not turning it into a Swiss army knife with a bottle opener and nail file.

### Details, Too

There are scores of little improvements. Rather than include some new effect, SOP adds wet/dry mix controls to the three different existing compressors as well as the Red Light Dist distortion, introduces another chorus mode, and cleans up the amp models in Ampire XT. Automation is now easier to use, mostly by improving how you work with automation points. MIDI editing includes legato and overlap correction, and there are subtle browser improvements, like being able to replace clips with drag-and-drop or add multiple clips simultaneously. You can even record a synth, bus, or ReWire output into an audio track—sort of like "re-amping" within the program. There are lots of little changes like this, all of which lead to a smoother overall experience.

### Conclusions

SOP 2.5 is a free update to current users, but for those who haven't experienced SOP, it's also a great place to start. SOP is a thoroughly modern DAW that leveraged a fresh start with a fresh code base into a clever, efficient program that has garnered a loyal (and growing) following; V2.5 remains true to SOP's original vision, while enhancing that vision's focus.



### PreSonus Studio One Professional Version 2.5 features:

- Editable folder tracks—cut, copy, paste, etc.
- Smooth, efficient take comping
- Enhanced effects, including wet/dry mix for compressors and distortion
- Free Softube Saturation knob to registered users
- Easier automation editing
- Re-record instrument, ReWire, and bus tracks into audio tracks
- No hit on workflow or speed despite numerous enhancements
- Efficient CPU usage and high-resolution audio engine

PreSonus's Studio One Professional Version 2.5 updates their popular software with features that add functionality, while retaining the program's trademark sleek workflow and speed. Order today from Musician's Friend and receive the best price and most reliable delivery service anywhere on the web.

Studio One Professional  
Version 2.5  
H78188

**\$399<sup>99</sup>**

For more PreSonus product visit: [musiciansfriend.com/presonus](http://musiciansfriend.com/presonus)

 audio-technica®



**A ATH-M50**  
45 mm drivers, 15Hz-28kHz. Choose from black (shown) or white finish.  
240569 from **\$159<sup>00</sup>**



**ATH-M30**  
40 mm drivers, 20Hz-20kHz.  
244501  
MSRP \$119.00  
**\$59<sup>95</sup>**



**\$20 INSTANT REBATE**

**ATH-M45**  
40 mm drivers, 15Hz-28kHz.  
241606 MSRP \$150.00  
**\$99<sup>99</sup> Before Rebate**  
**\$79<sup>99</sup> After Rebate**

**A. ATH-M STUDIO HEADPHONES**

**Professional studio monitor headphones.**

The ATH-M series headphones are made to monitor professional mixes. Audio-Technica has achieved an exceptionally accurate response for critical listening, and exceptional comfort for long sessions. Circumaural earpieces swivel 180° for easy one-ear monitoring and luxuriously padded ear cushions create an outstanding seal for maximum isolation.

**B. HD 280 PRO**

**Mix-worthy reference headphones.** The circumaural design offers up to 32dB external sound attenuation making them ideal for noisy environments, live shows, and DJ use. Ruggedly built with optimum sensitivity – these babies are LOUD! Smooth frequency response from 8Hz-25kHz. Collapsible earcups make them easy to stow. Ear pads, headband, padding and cable are easily replaceable.

**C. DT 770 PRO**

**For critical monitoring needs.** Closed-back, diffuse-field headphones feature bass reflex technology for improved bass response, and clinically accurate high and midrange reproduction. Rugged headband construction. Single-sided cable. 5Hz-35kHz frequency range. See our website for additional specs.

 **SENNHEISER**



**B HD 280 Pro**  
242411 **\$99<sup>95</sup>**

**beyerdynamic** 

**\$20 INSTANT REBATE**



**C DT 770 PRO**  
272025 MSRP \$249.00  
**\$229<sup>99</sup> Before Rebate** **\$209<sup>99</sup> After Rebate**



**D HD 201 Pro**  
242417 **\$29<sup>95</sup>**

**SHURE**®



**E SRH440**  
502252 MSRP \$125.00  
**\$99<sup>99</sup>**



**F HD205 II**  
430813 **\$69<sup>95</sup>**



**G SRH240A**  
H80446 MSRP \$75.00  
**\$59<sup>99</sup>**

**D. HD 201 PRO**

**The ideal entry into the world of powerful stereo sound.** Good attenuation of ambient noise; outstanding wearing comfort; and rich, crisp bass response. 21Hz-18kHz response. Includes 1/4" adapter.

**E. SRH440**

**Enhanced frequency response delivers accurate audio across an extended range.** With Shure's reputation for sound quality and extreme durability, the SRH440 will deliver in the studio or at home for years to come. Its closed-back, circumaural design rests comfortably over the ears and reduces background noise. Impedance, power handling, and sensitivity are all calibrated for professional audio devices such as DJ mixers, mixing consoles, and headphone amplifiers.

**F. HD205 II**

**Designed with exceptional sound and comfort for DJs.** Studio-grade detail and frequency response coupled with brilliant shielding of ambient noise. The rotatable earcup, and single-sided cable, make them ideal for DJs and home recording. Unlike competitive headphones, the earcup rotates while maintaining earpad contact on your head for stability and comfort without leaking noise into adjacent microphones. Includes a convenient protective pouch and locking 1/4" adapter.

**G. SRH240A**

**Excellent sound reproduction and comfort.** Optimized 40mm neodymium dynamic drivers help these headphones reproduce deep bass with clear mids and highs. The impedance, power handling and sensitivity are calibrated for connection to most audio devices. Re-engineered headband & ear cup construction provide ergonomic, comfortable fit. Includes a threaded 1/4" nickel-plated adapter.



**Auralex**  
acoustics

**A Project Studio Kit**  
421724 MSRP \$239.99 **\$219<sup>99</sup>**

**A. PROJECT STUDIO KIT**  
**Get your room sound mix-ready in no time.**  
Your final mixes will only be as good as your room is. Keep the walls and ceilings from coloring your music, and get the most out of your gear. The acoustics kit contains 6 - 1' LENRD bass traps, 24 - 1' x 1' x 1" Studiofoam panels, 2 - MoPAD SE Monitor Isolator pads, and two tubes of Tubetak Pro Liquid adhesive to put them all up.

**B. ROOMINATOR PROJECT 2**  
**Kill unwanted reflections!** Takes the guesswork out of acoustics and makes it easy to tame nasty sound problems. Designed primarily for rooms with less than 100 square feet of floor space. Kit contains 24 Studiofoam wedge panels (2' x 2' x 2"), 8 LENRD bass traps, and 5 Tubetak pro adhesives.

**C. MS-90/36 STUDIO MONITOR STANDS**  
**Isolate your monitors with these stylish 36" tall stands.** MS-90/36 studio reference monitor stands are 36" tall column-style stands made of sturdy, Series 6000 aluminum, and are designed for both exceptional support as well as practicality and style. They feature three internal cable channels that run the length of the column, giving you the opportunity to run a power cable and audio cable through two, while filling the third with sand or shot for even more stability.

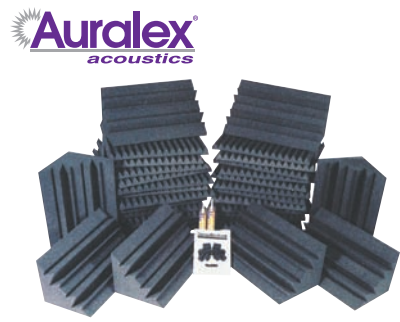

**B Roominator Project 2**  
421192 MSRP \$879.99 **\$659<sup>99</sup>**



**C MS-90/36 Studio Monitor Stands**  
H79168 MSRP \$319.99 **\$239<sup>99</sup> pr**

**D. REFLECTION FILTER X**  
**Filter out unwanted audio.** It's important not to let the room affect your mic's signal. The Reflexion Filter X offers an ideal, and cost effective solution to reduce unwanted audio reflections, especially when tracking vocals. The RF-X features a 4-layer acoustic filter and a lightweight clamp assembly that's quick to install to almost any mic stand.



**D Reflexion Filter X**  
H92115 MSRP \$149.00 **\$119<sup>00</sup>**



**E STPF2 Professional Mesh Pop Filter**  
712676 MSRP \$39.99 **\$19<sup>99</sup>**

**E. STPF2 PROFESSIONAL MESH POP FILTER**  
**Ensures clean vocals every time.** The STPF2 pop filter uses a carefully spaced dual-layer mesh to dissipate plosive energy from "b" and "p" pops while retaining sonic transparency. Included gooseneck and mounting hardware easily attach to any mic stand.

**F. ISO-L8R STUDIO MONITOR STANDS**  
**Isolate your studio monitors.** The ISO-L8R speaker stands are designed to isolate your speakers, effectively eliminating energy transfer to surrounding surfaces, preventing coloration of frequencies. Bass becomes tighter, and overall image is enhanced, allowing your speakers to perform to their full potential.



**F ISO-L8R155 Studio Monitor Stands**  
Small: 6.10" x 7.5"  
H85113 MSRP \$119.99 **\$99<sup>99</sup> pr**



**ISO-L8R 200 Studio Monitor Stands**  
Large: 7.8" x 10.0"  
H90796 MSRP \$179.99 **\$149<sup>99</sup> pr**

**MORE**

For our complete collection, search [musiciansfriend.com](http://musiciansfriend.com) for:

studio furniture

**GO**



**\$30 INSTANT REBATE**

**A 46" Desk - Maple**

46" wide work space, two 4-space racks, four casters (2 locking), height adjustable, and desk shelf for monitor and speakers.

H74599 MSRP \$599.99

**\$299<sup>99</sup> Before Rebate** **\$269<sup>99</sup> After Rebate**



**\$20 INSTANT REBATE**

**30" Desk - Cherry**

30" work space, one 4-space rack, four casters (2 locking), height adjustable, and desk shelf for monitor and speakers.

H74597 MSRP \$399.99

**\$199<sup>99</sup> Before Rebate** **\$179<sup>99</sup> After Rebate**



**\$10 INSTANT REBATE**

**24" Side Car - Cherry**

12-rackspace rolling sidecar, 24"W work surface, and 4 casters (2 locking). Height-adjustable.

H74601 MSRP \$199.99

**\$129<sup>99</sup> Before Rebate** **\$119<sup>99</sup> After Rebate**

**A. STUDIO FURNITURE**

**Desks and additional rack space.** With features found in much more expensive studio furniture, Studio Trends furniture combines sturdy construction, modern ergonomics, and eye-catching designs to help you create your ideal recording and editing environment.

**B. OMNIDESK**

**Audio/video editing workstation with professional layout.** The OmniDesk is a versatile and ergonomic workstation that provides an ideal environment for audio / video editing or music production equipment, monitoring traffic, handling dispatch, emergency calls, or other communication center production needs. It is pictured with optional KMSOM, OM13DL, and OM13R (sold separately).

**C. PRESTO STUDIO DESK**

**Affordable, ergonomic workspace for your cramped home or project studio!** The desk surface accommodates large keyboard controllers, control surfaces, and smaller mixers while offering 8 rackspaces in 2 bays within easy reach. The shelf above the rackspaces will hold near field monitors or displays; the shelf below is ideal for your CPU or storage. An optional sliding keyboard tray is available (Item 548083).

**D. PRODUCER STATION**

**The solution for organizing and holding all your studio gear.** The main tier holds an 88-key keyboard and dual 20-space racks on each side keep your rack gear squared away. An 8-space rack holds additional equipment on top, and there are dual 8-space CD holders. The upper tier accommodates additional keyboards or a computer monitor. 2 smaller sliding tiers hold computer keyboards. Cable organizers eliminate tangles. Locking casters make the whole system easy to move. 72"W x 41"H x 30"D.

**E. MUSICIAN'S GEAR SMALL WORKSTATION**

**A comfortable and efficient desk for your production environment.** Sturdy enough to support all of your computer and keyboard gear, the compact Z-frame and slide-out keyboard tray keep your setup sleek and clean. 43"W x 37-1/2"H x 30"D. Stand adjusts from 25"-28". 175lb. capacity.

**OMNIRAX**  
STUDIO FURNITURE  
for the discriminating musician



**B OMNIDesk**

H72822 MSRP \$1525 **\$1067<sup>50</sup>**



**C Presto Studio Desk**

548080 MSRP \$795.00 **\$556<sup>50</sup>**

**Studio**  
READY TO ASSEMBLE



**D Producer Station**

546553 MSRP \$599.00 **\$499<sup>99</sup>**

**MUSICIAN'S GEAR**



**E Musician's Gear Small Workstation**

542052 MSRP \$299.99 **\$169<sup>99</sup>**

musiciansfriend.com

800-217-5207

RECORDING | studio furniture

19

**NI NATIVE INSTRUMENTS**



**FREE D16 Group Drumazon 909 Emulation Software**  
(\$125.00 value) with H92989 or H92990

**KOMplete 9** is the next generation of NI's most comprehensive collection of virtual instruments and studio-quality effects. If you're looking for one package of software to enhance your workflow, this is it. Now with up to 65 total products in the Ultimate version, including Monark, Battery 4, and more, you are guaranteed the widest possible range of cutting-edge music production tools.

**KOMplete 9**  
33 products in total, with 120GB of samples.  
H92989 MSRP \$559.00  
**\$499<sup>00</sup>**

**KOMplete 9 ULTIMATE**  
65 products in total, with 370GB of samples.  
H92990 MSRP \$1099.00  
**\$999<sup>00</sup>**



**FREE SUGAR BYTES Thesys**  
(\$129.00 value) with 729000

**Omnisphere**

**Powerful, virtual synth with incredible sampling technology.** Along with realtime hybrid synthesis types and an innovative modulation routing system, Spectrasonics has pioneered several types of sampling. Its vast library includes unique psychoacoustic sounds and sound sources created with a composite morphing technique that transfers the harmonic characteristics of one instrument to another.

729000 MSRP \$499.00 **\$479<sup>00</sup>**



**Ivory II Grand Pianos**

**An unprecedented new level of realism.** Ivory II now features a bold new technology to create sympathetic string resonance. Notes struck excite the actual complex overtones of notes being held in the same manner that undamped strings ring in a real acoustic piano. To complete the sonic picture, it provides up to 18 velocity layers per piano, half-pedaling, pedal noise, lid position, timbre-shifting, parametric EQ, tuning tables, and more.

H14054 MSRP \$349.00 **\$319<sup>00</sup>**

**SONiVOX**  
sound that rocks.



**MAIL-IN OFFER**  
**FREE Alesis Q25 controller** (\$179.00 MSRP) with H81537

**Dubstep Destruction Tools**

**Four titles for dubstep music production.** This software contains Sonivox's best tools for dubstep production. Wobble is a tempo-synced modulation generator, Pulse provides MPC-style editing, Vocalizer is an innovative tool for vocal synthesis, and Twist lets you morph between timbres and create complex envelopes. These tools help you create dubstep mixes that will test the conflict between your desire to create and your desire to destroy.

H81537 MSRP \$649.99 **\$249<sup>99</sup>**



**MAIL-IN OFFER**  
**FREE Arturia Player 25 key controller**

**V Collection 3**

**A killer bundle of vintage software synths.** The V Collection 3 contains the most sought-after synths ever in one package, including Minimoog V, Moog Modular V, CS-80V, ARP2600 V, Prophet V, the Prophet VS, the Jupiter 8-V, Analog Laboratory, SEM V, Wurlitzer, and Vintage Drum Machines.

H81706 MSRP \$499.00 **\$399<sup>00</sup>**

**FREE Image Line Sawyer Synth VI**  
(\$99.00 MSRP) with H81706



**FREE Big Fish 4GB thumb drive with the hottest loops and samples**  
(\$49.99 value) with H91116 or H92813



**Spark Dubstep**  
H91116 MSRP \$129.00 **\$99<sup>00</sup>**

**Spark EDM**  
H92813 MSRP \$129.00 **\$99<sup>00</sup>**

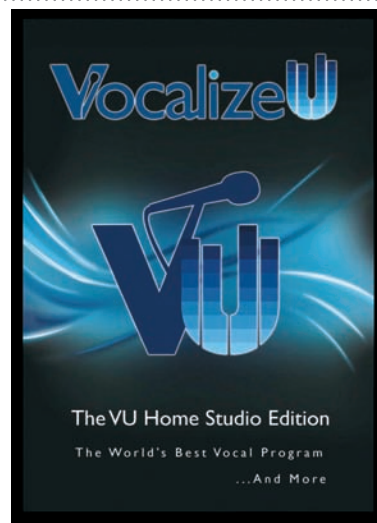

**VocalizeU Home Studio Edition**

**World-class vocal training software.** The VocalizeU Home Studio Edition is a practical software program with training applications that provide world-class vocal and musical education. With the VocalizeU program, each warm-up, lesson, and evaluation is personalized. The customizability of the vocal program caters to your individual singing needs, allowing you to work on areas of your voice at your own pace.

H95541 **\$69<sup>99</sup>**

# Ableton

**FREE SUGAR BYTES  
Artillery II**  
(\$199.00 value) with H92663 or H92662

**NEW**



- A Live 9 Standard**  
3 instruments, 37 effects, 11GB of sounds.  
H92663 **\$499<sup>00</sup>**
- Live 9 Suite**  
9 instruments, 40 effects, 50GB of sounds.  
H92662 **\$799<sup>00</sup>**

# steinberg



**FREE D16 Group Drumazon  
909 Emulation Software**  
(\$125.00 value) with H90060

- B Cubase 7**  
H90060 MSRP \$599.99 **\$499<sup>99</sup>**

**A. LIVE 9**  
**Create, produce, and perform.** Ableton introduces the latest iteration of their flagship DAW. With Live 9 you can easily browse for new sounds, instantly capture your performance, extract MIDI from audio, enhance your sound with improved studio effects, and then take your performance straight to the stage.

**B. CUBASE 7**  
**The wait is over.** The seventh generation of one of the best-reviewed and most capable DAWs has just arrived, setting new milestones in digital audio production. In Cubase 7, Steinberg has completely overhauled its famed MixConsole interface, guaranteeing stellar mixing capabilities with luxurious workflow improvements.

# cakewalk



**FREE Big Fish  
4GB thumb drive with the  
hottest loops and samples**  
(\$49.99 value) with H89412

- C SONAR X2 Producer**  
H89412 MSRP \$599.00 **\$499<sup>00</sup>**

**C. SONAR X2 PRODUCER**  
**Unprecedented integration, seamless workflow.** This is the full version of SONAR X2, and contains all of its core audio, features and capacities, including state-of-the-art tools for recording, performance, editing, mixing, mastering, and final web delivery of finished projects. The X2 is a refinement of the original, and loaded with enhancements like the Skylight interface that facilitates easy session management with a single Smart Tool.

**D. FL STUDIO 10 PRODUCER**  
**Full audio recording and post-production.** Providing the highest level of functionality for FL Studio, Producer gives you comprehensive audio recording and manipulation capabilities; playlist pattern, audio, and automation clips for arranging, chopping, stretching, and time-shifting; a modular synthesizer and effects creation environment with unlimited potential; and much, much more. Includes a free upgrade to FL Studio 11.



**FREE Big Fish  
4GB thumb drive with the  
hottest loops and samples**  
(\$49.99 value) with H74338

- D FL Studio 10 Producer**  
H74338 MSRP \$269.00 **\$199<sup>00</sup>**



**FREE Image Line  
Toxic Biohazard**  
(\$79.00 value) with H84532

- E Mixcraft Pro Studio 6**  
H84532 MSRP \$199.99 **\$149<sup>99</sup>**

**E. MIXCRAFT PRO STUDIO 6**  
**Powerful music creation and recording tool.** The Mixcraft name has always been known as a well-equipped, highly intuitive audio recording program that orients itself at an affordable price point, and Mixcraft Pro Studio 6 is the most capable version yet. Apart from the expected music creation, recording and mixing tools, it features many advanced plug-ins usually found only on more expensive audio software suites.

**F. R-MIX AUDIO PROCESSING SOFTWARE**  
**Isolate individual components of a mix.** R-MIX allows you to select components of the mix and edit them individually. You can change panning and levels to individual instruments within a mix, and add effects to each element as desired. You can even independently adjust the pitch and speed of the playback.



**\$50 INSTANT  
REBATE**

- F R-MIX Audio Processing Software**  
H81589 MSRP \$249.00  
**\$199<sup>00</sup> Before Rebate** **\$149<sup>00</sup> After Rebate**



- G MAGMA**  
H85634 MSRP \$199.00 **\$179<sup>00</sup>**

**G. MAGMA**  
**Rackmount graphical interface, vintage processor emulation.** MAGMA is a Virtual Studio Rack loaded with 65 all-new effects. Featuring an appealing and intuitive 1-rack-unit interface, MAGMA invites experimentation and sounds incredible with every tweak. Using its flexible routing matrix, you can build FX chains that will excite your imagination.

NEW



# propellerhead

**FREE Big Fish**  
4GB thumb drive with the  
hottest loops and samples  
(\$49.99 value) with H95539 or H95540

## Reason 7

The latest from one of the greatest. Reason 7 is here. The latest incarnation of one of the world's favorite music software packages brings a wide variety of enhancements to help you create more and better music. From start to finish, its ever-expandable, freely routable rack of instruments, effects and sounds has everything you need to write, record, remix and produce great-sounding tracks.

H95539 MSRP \$449.00 **\$399<sup>00</sup>**

Reason 7 Upgrade  
H95540 **\$129<sup>00</sup>**



—||— bigfishaudio

**FREE Big Fish**  
Studio Kit Builder  
(\$199.95 MSRP) with H95722

## SWAGG (Kontakt Player 5/Plug-in)

Huge-sounding virtual instrument that makes sound design fast and easy. SWAGG is the new virtual instrument developed by VIP Loops in collaboration with Big Fish Audio. The sounds are huge and designed to cut through any mix, based the hottest sounds that create today's hip-hop, R&B, pop, and soul hits. Containing over 8GB of samples and 345 patches designed for urban music production, SWAGG delivers sounds that allow you to create top notch productions.

H95722 **\$199<sup>95</sup>**



## Steven Slate Drums SSD4 Platinum Virtual Instrument

A full library of impeccably recorded drums. Features state-of-the-art Mac/PC (VST, RTAS, AU) drum sampler that makes loading, customizing, and mixing kits, loading and auditioning MIDI grooves, customizing MIDI maps, and routing to your workstation easy. Even load your own drum samples. Has 100 kits, including reprogrammed classic Slate "Mix Ready" kits and new Soul-tone Cymbals.

H81741 MSRP \$399.99 **\$199<sup>99</sup>** Before Rebate **\$149<sup>99</sup>** After Rebate

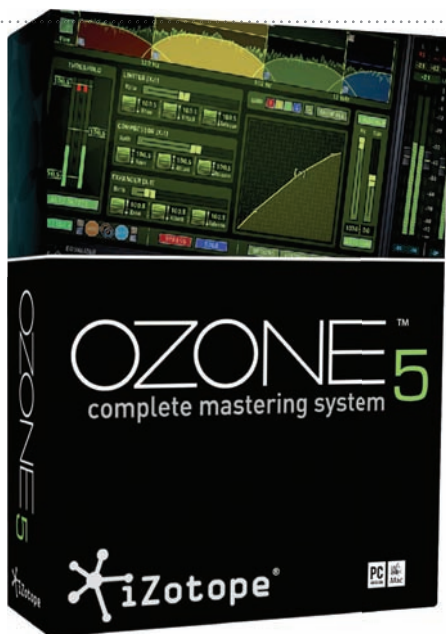

iZotope

## Ozone 5 Complete Mastering System

Sophisticated mastering software tool with eight different components. Mastering makes the difference between a good-sounding mix and a professional-sounding master. With Ozone 5, iZotope makes it easier than ever for anyone to master songs efficiently. Ozone 5 includes eight essential mastering tools: Maximizer, Equalizer, Multiband Dynamics, Multiband Stereo Imaging, Post Equalizer, Multiband Harmonic Exciter, Reverb, and Dithering.

H79574 MSRP \$249.00 **\$199<sup>00</sup>**

## PRO TOOLS 10



### Pro Tools 10 Ignite! The Visual Guide for New Users (Book/CD)

This book presents what you need to know about Pro Tools 10, with easy-to-follow instructions and screen shots that make it simple to use.

H91109 MSRP \$34.99 **\$31<sup>49</sup>**

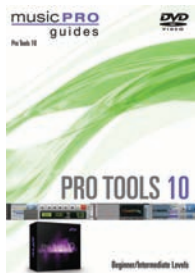

### Pro Tools 10 Beginner/Intermediate Level Music Pro Guide Series (DVD)

H87795 MSRP \$39.99 **\$35<sup>99</sup>**

### Pro Tools 10 Advanced Level Music Pro Guide Series (DVD)

H87804 MSRP \$39.99 **\$35<sup>99</sup>**



### Pro Tools 10 Power! The Comprehensive Guide (Book)

A complete guide to Pro Tools, covering the details of the Pro Tools interface, as well as editing, mixing, MIDI, synchronization and more.

H81650 MSRP \$44.99 **\$40<sup>49</sup>**



### Pro Tools 101 (Book/CD)

Now updated for Pro Tools 10 software, this book and cd kit takes a comprehensive approach to learning the fundamentals of Pro Tools systems, with everything you need to know to complete a project.

H91108 MSRP \$49.99 **\$44<sup>99</sup>**

## REASON 6



### Reason 6 Ignite! The Visual Guide for New Users (Book)

The popular introductory guide to Propellerhead's flagship DAW, REASON 6 IGNITE!, is a completely updated edition, ready to introduce new users to this fun and powerful music-making software.

H81649 MSRP \$29.99 **\$26<sup>99</sup>**



### Reason 6 Advanced Level Music Pro Guides (DVD)

H82546 MSRP \$39.99 **\$35<sup>99</sup>**

### Reason 6 Beginner/Intermediate Level Music Pro Guides (DVD)

H82543 MSRP \$39.99 **\$35<sup>99</sup>**



### Reason 6 Power! The Comprehensive Guide (Book)

This book goes deeper into Reason 6, and explains why certain features are used and when they are most beneficial to your project, giving you a better understanding of the program.

H81651 MSRP \$39.99 **\$35<sup>99</sup>**

## RECORDING



### Hal Leonard Recording Method - Book 6 (Book/DVD)

Take your song from mix to master. Detailed illustrations, photographs, plus audio and video examples on DVD make sure you understand everything you need to know to mix and master like the pros.

H87794 MSRP \$39.99 **\$35<sup>99</sup>**

## ABLETON LIVE



### Ableton Live 8 Power! The Comprehensive Guide (Book)

This is the all-inclusive guide to making music with Ableton Live 8. Written for beginners to pros, this book explores the program's fundamental features, as well as additional tips and tricks.

H73002 MSRP \$39.99 **\$35<sup>99</sup>**



### Producing Music With Ableton Live (Book/DVD)

Start producing your own music from the ground up! Learn the rich uses of Ableton Live including making beats, remixing, live recording, looping, sound design, and more.

H81824 MSRP \$16.99 **\$15<sup>29</sup>**

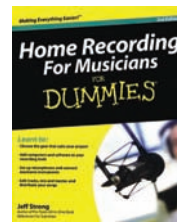

### Home Recording For Musicians For Dummies (Book)

This book shows you how to set up a home studio, record and edit your music, master it, and even distribute your songs. With this user-friendly guide, you'll gain the skills to manage your sound.

H79432 MSRP \$24.99 **\$22<sup>49</sup>**



### Hal Leonard Recording Method - Book 3 (Book/DVD)

Discover how to get the most out of your recording software and plug-ins with the 3rd installment of Hal Leonard's Recording Method, with practical insights and insider tips.

H82548 MSRP \$39.99 **\$35<sup>99</sup>**

## LOGIC PRO 9



### Logic Pro 9 Advanced Music Pro Guides (DVD)

Logic Pro 9 streamlines the technical side of things, so you can record, edit, and mix it, too. Now you can easily put the power of the most advanced tools to work for your projects.

H91105 MSRP \$39.99 **\$35<sup>99</sup>**



### Power Tools for Logic Pro 9 (Book/DVD)

Book and DVD that will unravel any mystery that remains in your exploration of Logic 9. Logic is a deep program, and this material will illuminate all.

H91106 MSRP \$39.99 **\$35<sup>99</sup>**

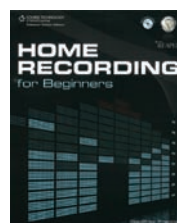

### Home Recording for Beginners (Book/CD)

A step-by-step guide through the fundamentals of home recording. Delivered over the course of 30 lessons, with real examples to try out. Perfect as a starter text for any entry-level class.

H72995 MSRP \$34.99 **\$31<sup>49</sup>**



### Recording Method - Instruments & Vocal Recording 2nd Ed (Book/DVD)

Addresses new equipment and software concerns that affect the way excellent recordings are made. Learn what you need to know about capturing the best vocal and instrument tracks possible.

H79068 MSRP \$39.99 **\$35<sup>99</sup>**

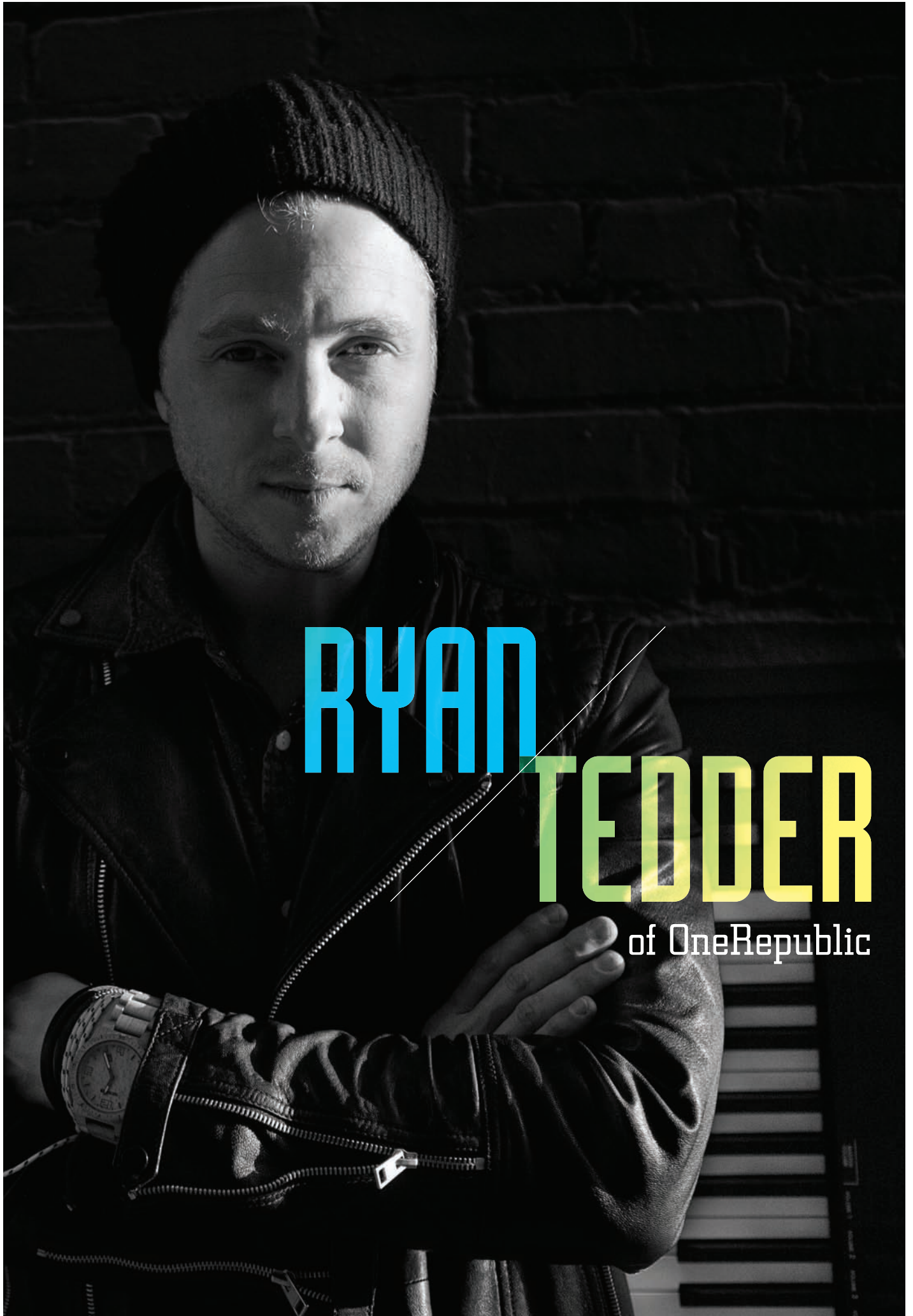

**RYAN**  
**TEDDER**  
of OneRepublic

Since 2007, OneRepublic's Ryan Tedder has had a huge impact on music charts all over the world as a singer, songwriter, multi-instrumentalist and producer. There are the OneRepublic hits he's helped pen, including "Apologize," "Stop and Stare," "All The Right Moves," and, most recently, "Feel Again." He's also co-written or produced for others including Leona Lewis, Gavin Degraw, Colbie Caillat and Beyonce, not to mention his recent Grammy win as one of the producers of Adele's juggernaut album 21. Recently we were able to talk to the prolific artist about his personal journey as a musician who developed into a producer, and the perseverance of OneRepublic.

So where did Tedder get his deep passion for music? For one, it's in his blood. "My dad was a gospel songwriter. He was like a published songwriter way back in the day and he turned me on to songs. My upbringing endowed me with an advantage in melody partly because of my dad's just absolute bombardment of popular music to me at all times." The other half he blames on church. "For singers, that makes sense, right? 'Cause you're in a choir, as I was. But for writing big songs, a spiritual or sacred song, is designed, that by the time you make it to that second chorus it has to be hooky and simple enough that you are part of the worship and not a bystander."

Ryan was quick to emulate his father, jumping on the piano in the basement at the precocious age of 3, but it would take him a while before he was able to find a love for singing solo in front of a crowd. "I'd always had a certain knack for singing ... so my choir teachers had said, and my piano teachers ... and I quietly sang every single day that I could

possibly remember from the time I was nine or 10. I'd go in my closet and shut the door 'cause it was sound baffling with all the clothes. I didn't want my mom to know." Though he was only allowed to listen to Christian music at home, he did have a Pet Sounds cassette, and developed a taste for Britpop acts like Doves and Oasis, as well as more established acts like U2 (Tedder respected the fact that Bono was also raised in a Pentacostal Assembly of God) and Peter Gabriel.

His senior year, the family moved to Colorado Springs where he met his OneRepublic bandmate Zach Filkins. "Probably the only thing traditional about this band is how he and I came together. After like the second or third soccer practice, I didn't have a car, and he offered to take me home. I get in the car and he's playing Oasis, I think, and I was like, 'No way, you like Oasis? That's awesome.' And he's like 'Aw man, music's my life.' A few months later, the two teammates competed in a Battle of the Bands with Tedder behind the drums (one of the many instruments he's adept at) and the Barcelona-bred Filkins on guitar. It was shortlived, however, as they both attended different colleges. At Oral Roberts University Tedder, who'd

...I would just study his [Clapton] riffs and would sit there literally and just play til my fingers bled.

already began writing songs on piano and drums, picked up a habit other than schoolwork. "My freshman year, my roommate had an acoustic guitar, and that was it. I skipped class and played acoustic guitar. I had all these tutorials on how to play guitar and I was at that point going through my Clapton phase, so I'd buy anything Clapton, and I would just study his riffs. I would sit there and just play til my fingers bled."

He did manage to right the ship and graduated with a degree in PR and Advertising, landing an internship at Dreamworks Publishing in Nashville as a runner. One day he saw a flier for

a singer/songwriter competition that included a record deal and appearance on MTV, and decided to audition. He won the Nashville regional, and then it was off to New York where he nervously took the stage on TRL, in front of judges Pink and Brian McKnight, and beat out four others with just an acoustic guitar singing a Babyface-like ballad called "The Look."

The MTV deal didn't amount to much, but it did get him noticed by the hottest producer of the era, Timbaland, who spent a year trying to track the young man down, wanting to add him to his stable of producers and songwriters. It was during the next year and a half, while Timbaland was blowing up artists like Missy Elliott, Justin Timberlake, and Nelly Furtado that Ryan would learn many tricks of the trade that have made him successful as a producer and songwriter today. It was also where he crafted what would later become the first of his many hits. "When I did 'Apologize' I didn't have a drummer. It was just me. So I laid the piano down. I didn't even know how to make a click track, like a tempo to map out to record to. The only thing I did know how to do was use an MPC drum machine. So I play it on the piano and the only drums sounds I had were, you know, Timbaland sounds. So it was like (imitates beats). So I'm using what I got. It was super limited, super minimal, but there was this cool honesty to it, and it resonated emotionally."

In 2002, armed with "Apologize" and a few other ideas, he headed out west to Los Angeles where he was able to convince his old classmate to rejoin him in the pursuit of fame and fortune. They rounded out the band (at the time Republic) with another guitarist, Drew Brown, Brent Kutzle on bass and cello, and Eddie Fisher on drums/percussion. In the course of three months they played two gigs and recorded a five-song demo in Tedder's bedroom. The demo landed them a meeting with A&R rep Wendy Goldstein of Capitol Records. He described it as "the craziest, wackiest meeting. I mean we talked about Radiohead 'cause that was one of our other favorite bands. And she said, 'Well I'm not signing you, but I wanted to meet you. Go out and book every possible

show you can book and play your asses off and I'll see you in a year."

The band was completely deflated, thinking they had a record deal, but they went out and took her advice. They became regulars in the lineups of all the Sunset Strip clubs, and by May of 2004, they finally had enough of a following to sell out a show at the Roxy. They ended up doing a few more showcase performances, and signed later that year to Velvet Hammer, a Columbia Records subsidiary. They recorded an album that included what would eventually become their second hit "Stop and Stare", with producer Greg Wells (who'd worked with Deftones). The record release date was set for 6/6/6 which Tedder thought was somewhat ominous considering his background. "My mom was like 'It's the mark of the beast. You want me to tell my friends to buy my son's record on the mark of the beast?' I'm not joking."

They were both right to be apprehensive. The band was dropped from Columbia two months before the album came out. Frustrated, Tedder uploaded "Apologize" and "Stop and Stare" on the band's MySpace page that night and switched their status to unsigned. They quickly became the number one unsigned act on the then-popular social media site. It didn't take long before an old friend reached out to the band, Timbaland. He said he wanted to sign them immediately and have the album come out on Interscope. While things were looking up, Tedder says the band was skeptical. "Timbaland took 'Apologize,' remixed it, and Interscope said 'We're going to put it on his album for exposure. We're going to bury it. It's going to be track 10 or 11. It's not going to be a single.'"

The band freaked out, thinking that having your first single be a remix on someone else's album was a recipe for disaster. It had quite the opposite effect, and by the time they released *Dreaming Out Loud*, the public was ready for more OneRepublic. Though they had had dreams of originally being alternative rock stars, the popularity of "Apologize" made them genreless, allowing them to evolve and have fun making whatever kind of music they wanted. The success

of the follow-up single "Stop and Stare" meant they weren't one-hit wonders. The success of their sophomore effort, *Waking Up*, with singles "All the Right Moves," "Secrets," and "Good Life" confirmed they were legit. As a bonus to their newfound success, Tedder was able to live out a dream opening up for his Pentacostal brother Bono on U2's 360 Stadium Tour.

Meanwhile, he's continued to pad his résumé by working with a wide variety of artists, including Cobra Starship, The Wanted, Carrie Underwood, Maroon 5, J.Lo, James Blunt, Gym Class Heroes, Natasha Bedingfield, Far East Movement, B.o.B., Chris Cornell, Backstreet Boys, Jordin Sparks, James Morrison, and many others.

The cover of OneRepublic's latest album, *Native*, is a collage of five animals, a reflection of how each member of the band is completely different from each other. It's no coincidence that the animal representing Tedder is a fox. In most cultures the fox symbolizes cunning, cleverness, adaptability, wisdom, determination, and focus. The red in the fur of a fox is believed to be a solar emblem that depicts passion, desire, intensity and expression. Then there's the phrase "crazy like a fox" which in some circles means unpredictable. All of these describe the 33-year old Oklahoma native's career to a tee.

As Tedder put it, "There's no rules. You don't get to choose. You can pick the path that you want to go down, but you have no idea if it that path forks or goes left or right around that bend. You just pick the path. Once you commit to it, you're on it and you think 'Oh, it's going over here,' but really it's going over here. So you take it and really do the best you can with it." In other words, if you really want to get into the henhouse, you've got to think like a fox.

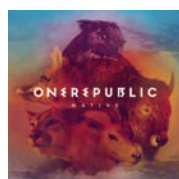

Pick up OneRepublic's new album, *Native*, wherever great music is sold.

The latest version of Ryan Tedder's go-to keyboard, the versatile MOTIF X8 has 741MB internal wave ROM offering realizing pianos, acoustic instruments, classic synths, and modern hip-hop sounds. It has an 8-element architecture with XSpanded articulation and 18 filter types for sound shaping, as well as 1,664 voices, 97 drum kits, and 512 performances combining 4 voice and 4 smart arpeggiators for backing tracks. It also features a 16-track sampling sequencer with 128MB of sample RAM for adding vocals, guitars, slice audio, loops, and more.



**YAMAHA MOTIF XF8 88-KEY  
MUSIC PRODUCTION SYNTHESIZER**

H64307 MSRP \$4,039.00 **\$3599<sup>99</sup>**

# M-AUDIO®



H92987



H92988

**Axiom 25 MK2**  
25 keys and 1 assignable slider.  
H92987 MSRP \$279.95 **\$199<sup>99</sup>**

**Axiom 49 MK2**  
49 keys and 9 assignable sliders.  
H92988 MSRP \$439.95 **\$299<sup>99</sup>**

**Axiom 61 MK2**  
61 keys and 9 assignable sliders.  
H92986 MSRP \$499.95 **\$399<sup>99</sup>**

## AXIOM

Building on an already amazing MIDI controller, the latest version of the Axiom series now comes with DirectLink technology that will automatically map onboard controls to common DAW functions, and Axiom's Instrument Mode that instantly assigns virtual instrument parameters to hardware control. There's also a version of Ignite music software included to help you start creating.



H92731

H89900

H89899

## OXYGEN

These compact bus-powered controllers feature velocity-sensitive keys, 8 assignable MIDI knobs, programmable slider, dedicated transport controls, and track select buttons. DirectLink mode automatically maps controls to common DAW functions, and all are Pro Tools compatible right out of the box.

**Oxygen 25 MK3 Ignite**  
25 keys and 1 assignable slider.  
H89899 [see web for price](#)

**Oxygen 49 MK3 Ignite**  
49 keys and 9 assignable sliders.  
H89900 [see web for price](#)

**Oxygen 61 MK3 Ignite**  
61 keys and 9 assignable sliders.  
H92731 [see web for price](#)



H88545

H88544

H88543

## AXIOM A.I.R.

M-Audio's Axiom A.I.R. are a highly evolved series of keyboard controllers, with exclusive Hypercontrol automatic-mapping technology and groundbreaking Ignite software from Avid to provide you with an instant, fully immersive music creation experience.

**Axiom A.I.R. mini 32**  
H88544 [see web for price](#)

**Axiom A.I.R. 25**  
H88543 [see web for price](#)

**Axiom A.I.R. 49**  
H88545 [see web for price](#)

# novation®



H93072

## LAUNCHKEY

Novation's Launchkey line of MIDI controllers are loaded with up to 50 physical controls including 16 velocity-sensitive, multi-colored launch pads that can trigger and stop clips and scenes inside Ableton Live. More than your standard controller, Launchkey is an integrated software/hardware instrument that can also be used with the Launchkey and Launchpad apps for iPad.

**Launchkey 25**  
25 keys  
H93074 MSRP \$199.99 **\$149<sup>99</sup>**

**Launchkey 49**  
49 keys and 9 assignable sliders.  
H93072 MSRP \$249.99 **\$199<sup>99</sup>**

**Launchkey 61**  
61 keys and 9 assignable sliders.  
H93073 MSRP \$299.99 **\$249<sup>99</sup>**



H78020

## IMPULSE

These semi-weighted keyboard controllers with aftertouch and automap control software make assigning knobs, faders, buttons and controlling your DAW a cinch. They include backlit drum pads, large LCD screen display, Ableton Live Lite, Novation's Bass Station synth, and a Loopmasters sample pack. The slate grey with red trim design fits any studio.

**Impulse 61**  
61 keys with 9 assignable faders.  
H78018 [see web for price](#)

**Impulse 49**  
49 keys with 9 assignable faders.  
H78020 [see web for price](#)

**Impulse 25**  
25 keys with 1 assignable fader.  
H78019 [see web for price](#)

# NI NATIVE INSTRUMENTS



The New MASCHINE MK2 and MASCHINE MIKRO MK2 pack a ton of upgrades into two stylish, extremely functional designs. Each version features improved touch-sensitive pads that can be assigned colors to easily identify sounds, patterns, groups and scenes. Additional improvements include timestretch and pitch shifting, host transport control, new auto-write automation function, master push encoder, and more.

**The New MASCHINE MIKRO MK2**  
Compact size; with 28 click buttons and single display. Available in white (shown) and black.  
H86858 MSRP \$399.00 **\$349<sup>00</sup>**

**The New MASCHINE MK2**  
Standard size; with 8 rotary knobs, 47 click buttons and dual displays. Available in black (shown) and white.  
H86859 MSRP \$669.00 **\$599<sup>00</sup>**

## novation

**NEW**



**Launchpad S**  
The Launchpad gets some refreshing enhancements. Novation's Launchpad is an instrumental choice when creating or performing music, and now the updated Launchpad S adds even more enhancements. The Launchpad S is class compliant (Mac, PC, iPad), features super bright LEDs, faster LED feedback, overlay stickers for DAW functions, and can be used with included Ableton Live edition or other major DAWs.  
H94950 MSRP \$219.99 **\$169<sup>99</sup>**

## AKAI professional MPC SERIES



**MPC Studio**  
Low-profile design, less than 1" thin with streamlined controls.  
H81343 MSRP \$999.00 **\$599<sup>00</sup>**

**MPC Renaissance**  
Classic hardware controls and an integrated pop-up display.  
H81342 MSRP \$1,999.00 **\$1299<sup>00</sup>**

The letters MPC have been synonymous with beat creation for years; with its legendary design the MPC has grown into an entire series of production controllers. Ranging from the slimmed-down MPC Studio to the full-featured MPC Renaissance, these next generation controllers fuse together a familiar workflow with the power of your computer for even greater power.

## Arturia

**FREE D16 Group Drumazon 909 Emulation Software**  
(\$149.00 MSRP) with H92999

**NEW**



**SparkLE**  
Hybrid software and hardware drum machine. SparkLE is the newest hybrid instrument from Arturia that will take your beat creation to new levels. The high-quality build construction of the SparkLE hardware and the amazing sound, workflow and creative tools in the award winning Spark Engine software make these combined powerhouses the ultimate beat-creating tools.  
H92999 MSRP \$299.99 **\$249<sup>00</sup>**

## Ableton

**NEW**



**Push**  
Get your hands on making music. Push is a fully cohesive and intelligent controller designed for absolute command of Ableton Live 9. With a hands-on approach to melody and harmony, beats, sounds, and song structure, Push puts the fundamental elements of music making at your fingertips. There are a total of 64 touch-sensitive pads that give you a number of different ways to create beats, step sequence arrangements, and navigate your loops – all at the same time.  
H92655 **\$599<sup>00</sup>**

28 More models. More colors. More styles. Visit [musiciansfriend.com](http://musiciansfriend.com)

NEW



**MX49**

**MOTIF sounds, motivating features.** The MX49 features carefully selected sounds taken from the MOTIF XS sound bank, all packed into a sleek 49-note version that fits today's mobile lifestyles. It's designed to bridge the gap between hardware and software, adding extensive MIDI USB connectivity, with advanced DAW and VST control.

H90405 MSRP \$799.00 **\$599<sup>99</sup>**

**MX61 61 Keys**

H92441 MSRP \$999.00 **\$799<sup>99</sup>**



**MOTIF XF6**

**Setting the standard for years to come.**

The next-generation Yamaha MOTIF XF builds on the decade-long heritage of

MOTIF and breaks new ground with Flash memory expansion capabilities. It's loaded with 741MB of internal Wave ROM that includes incredibly realistic pianos and acoustic instruments, vintage synths, and the hip-hop sounds that all of today's top producers are using.

H64308 MSRP \$2999.00 **\$2499<sup>99</sup>**

**MOTIF XF8 88 Keys**

H64307 MSRP \$4039.00 **\$3599<sup>99</sup>**

**MAIL-IN OFFER**  
**FREE MOTIF 10th Anniversary Premium Collection Pack**  
(\$499.00 MSRP)  
with H64308 or H64307

# YAMAHA



**MM8**

**Awesome power and control to create and perform your music!** Sounds from the pro-level MOTIF series

give the MM8 an enormous variety of dynamic, authentic voices. Includes an expressive 88-key graded hammer action keyboard and dynamic music creation tools such as automatic pattern and arpeggiator generators, performance memory for instant full-panel setting changes, and versatile multitrack song recording features. 32-note polyphony, 16-part multitimbral. Includes Cubase 4 software. See our website for all the details.

703325 MSRP \$1299.00 **\$899<sup>99</sup>**



**MOX6**

**Yamaha's most powerful workstations ever.**

The 61-key, semi-weighted MOX6 combines a MOTIF XS sound engine, MIDI keyboard controller

with extensive DAW and VST control, multichannel USB audio interface, onboard sequencer, and an extensive DAW/VST software bundle. Other features include 1,217 Voices, 355MB of waveforms, Expanded Articulation tone generation system, over 256 Performances, Virtual Circuitry Modeling, 4-part arpeggio engine, direct performance recording, and much more. Get full details at our website.

H74342 MSRP \$1499.00 **\$1199<sup>99</sup>**

**MOX8 88 Keys**

H74343 MSRP \$1999.00 **\$1699<sup>99</sup>**

H85116



H85114



H85115



# KORG

**Kronos X 61-Key Music Workstation**

The 61-key Kronos X builds upon the now-legendary Kronos Music Workstation and adds a larger SSD (and the ability to add another SSD for even more storage), and 2GB of available sampling RAM (3GB total) which gives you fast, direct access to even more of your sonic arsenal. Stunning sound, fast loading, and graceful workflow. See our website for a more complete description.

H85116 MSRP \$4000.00 **\$3199<sup>00</sup>**

**Kronos X 73-Key Music Workstation**

H85114 MSRP \$4600.00 **\$3699<sup>00</sup>**

**Kronos X 88-Key Music Workstation**

H85115 MSRP \$5,000.00 **\$3999<sup>00</sup>**

**Krome 61 Keyboard Workstation**

**An ideal workstation with expertly created, in-demand sounds.** The Krome is an ideal choice for any style of piano playing. This keyboard workstation offers full-length, unlooped samples of every key for a spectacular piano sound. Loaded with features and intuitive controls like a 7-inch color display, inspiring drum tracks, powerful FX, 640 Programs and 288 Combinations. Connect to your computer via USB, or use the included SD card for extra storage.

H88267 MSRP \$1499.00 **\$999<sup>00</sup>**

**Krome 88 Keyboard Workstation**

H88268 MSRP \$1999.00 **\$1599<sup>00</sup>**



# KingKORG

SYNTHESIZER

The new KingKORG modeling synthesizer rules the stage and storms the studio. KingKORG gives you the power to create and play sounds from yesterday, today, and tomorrow.

### 61 full-size keys...



...and our famous X/Y joystick let you rule over all you survey.

### 3 oscillators, 2 timbres, 24 voices.



Start with basic analog waveforms, then rise to power with dual waves, sync, cross mod, VPM, even PCM multisamples.

### A playable museum.



Along with a variety of new filters, KingKORG accurately models filters from classic synthesizers, such as our own MS-20.

### Real tube, real tone.



A real 12AX7 vacuum tube lurks beneath this grate. Use it to add natural warmth, smooth overdrive, and everything in between.

### Classic and modern effects.



Vintage effects model

classic stompboxes, along with distinctive sound-warping tools and rich ambience.

[KORG.COM/KINGKORG](http://KORG.COM/KINGKORG)



KingKorg

H93003 \$1299<sup>00</sup>

2 ways to shop | [musiciansfriend.com/korg](http://musiciansfriend.com/korg) | 800.217.5207



**\$30 PRICE DROP**

**A KeyStudio**  
H65531 MSRP \$129.95 **\$79<sup>99</sup>**



While Supplies Last

**\$30 PRICE DROP**

**B PSR E333**  
H73355 MSRP \$269.00 **\$129<sup>99</sup>**



While Supplies Last

**\$100 PRICE DROP**

**C MM6 Music Synthesizer Workstation**  
700813 MSRP \$699.00 **\$399<sup>99</sup>**



While Supplies Last

**\$100 PRICE DROP**

**D DGX 640C**  
H90117 MSRP \$1418.99 **\$599<sup>99</sup>**



**E MiniLab**  
H92998 MSRP \$129.00 **\$99<sup>00</sup>**



**F MS-20 Mini**  
H92992 MSRP \$860.00 **\$599<sup>00</sup>**



**G MiniNova**  
H88070 **see web for price**

**\$50 INSTANT REBATE**



**H Privia PX-5S Pro Stage Piano**  
H93996 MSRP \$1299.00 **\$999<sup>00</sup>**



**I KingKorg**  
H93003 MSRP \$1549.00 **\$1299<sup>00</sup>**



**J V-Combo VR-09**  
H93000 MSRP \$1165.00 **\$999<sup>00</sup>**

**A. KEYSTUDIO**

A great combo of Avid hardware and software – the 49-note, velocity-sensitive keyboard and Pro Tools SE music creation application – makes it easy to turn your inspiration into a professional-quality song. Also comes with over 100 virtual instruments and an extensive library of templates and loops for more inspiration.

**B. PSR E333**

This 61-key, touch-sensitive keyboard features 497 dynamic, natural sounding voices, 106 accompaniment styles, and 102 built-in songs. The Easy Recording feature lets you record up to 5 songs and save them into the onboard memory.

**C. MM6 MUSIC SYNTHESIZER WORKSTATION**

Lightweight and portable, this 61-key synth comes loaded with 418 voices and 22 drum kits, plus an extra set of GM voices, lots of realtime controls for performance and song creation plus 32-note polyphony, effects, 8-track sequencer, and USB port for computer connectivity with included Cubase LE.

**D. DGX 640C**

The DGX-640 was designed to be as close to a piano as a portable grand can be with its 88-key weighted Graded Hammer Standard keyboard action and wide selection of piano voices. The includes Yamaha Education Suite and USB connectivity both add functionality.

**E. MINILAB**

Designed to marry the style you love with the hands-on control and portability you need to take your studio wherever you are inspired. It gives you a great depth of features in a package that is also stylish and sturdy.

**F. MS-20 MINI**

Everything has been reborn from the original, including the robust sound, iconic analog filter, and versatile patching options. The same engineers who developed the original MS-20 have perfectly reproduced its circuitry and fit it into a body 86% of the original size.

**G. MININOVA**

MiniNova comes with 256 incredible onboard sounds that you can tweak with 5 knobs, or totally warp with 8 'animate' buttons. MiniNova also has a voice-tune effect and classic vocoder so you can recreate iconic vocal sounds.

**H. PRIVIA PX-5S PRO STAGE PIANO**

The PX-5S is part of Casio's line of Privia digital pianos and comes loaded with a lavish collection of acoustic pianos, vintage keyboards, and synthesizers. At the heart of the PX-5S is Casio's proprietary AiR sound source that provides incredibly realistic grand piano sounds.

**I. KINGKORG**

KingKORG is a full-fledged, knob-driven analog modeling synthesizer that musicians have been waiting for. It carries on the design philosophy of classic Korg analog synths while retaining all of the conveniences of a modern keyboard. This exciting, hands-on synth can model a huge variety of oscillators, plus a library of filters from sought-after vintage synthesizers.

**J. V-COMBO VR-09**

Travel-ready, affordable, and outfitted with top-level Roland sounds, the V-Combo VR-09 is the ideal all-in-one solution for performing keyboard players. Dedicated piano, organ, and synth sound engines—organized in three intuitive blocks on the front panel—provide all the essential tones you need, right under your fingertips.



H95719

### PSR-E243 Portable Keyboard

**Great-sounding, features-rich beginner's model.** Primarily geared toward learning musicians, the PSR-E243 offers the built-in Yamaha Education Suite, which enables students to teach themselves piano as well as built-in accompaniment styles that make it possible to sound like full bands. USB TO HOST connectivity makes interfacing with personal computers and iPad/iPhone/iPod touch easy. 385 sounds, 110 Styles.

H95720 MSRP \$169.00 **\$99<sup>99</sup>**



H95720

### PSR-E343 Portable Keyboard

**Touch-sensitive, 550 sounds, 136 Styles.** The PSR-E343 offers touch-sensitive keys, powerful speakers, hundreds of sounds, dozens of Styles, and USB TO HOST connectivity, which makes interfacing with computers easy. It also has an AUX line input and Melody Suppressor so players can perform the lead part in their favorite songs stored on MP3 players.

H95719 MSRP \$269.00 **\$159<sup>99</sup>**

### PSR-S650 61-Key Arranger Workstation

**Expand your musical world.** With Yamaha's MegaVoice technology for ultra-realistic instrumental Style backing – especially with guitar sounds – the 61-key PSR-S650 has 864 sounds, 181 ready-to-perform styles, and 64-note polyphony. You can create custom styles and tunings and record to its 16-track sequencer. It features FlashROM Expansion to load Expansion Packs containing new audio samples; ethnic, regional, and traditional Voices and Styles; and also functions as a multi-timbral tone generator via USB.

H78482 MSRP \$999.00 **\$799<sup>99</sup>**



H88743

### PSR SERIES

**T**he PSR series are a line of topnotch, 61-key arranger workstations featuring Real Distortion DSP for high-quality guitar tones. FlashROM Expansion provides more Voices and Styles and you can assign and trigger audio with its Audio Link Multi-Pads. A redesigned sound system gives you increased fidelity efficiency and tweakability.

### PSR-S750 61-Key Arranger Workstation

678 voices, 325 styles, and unlimited songs.  
H88743 MSRP \$1499.00 **\$1199<sup>99</sup>**



H88744

### PSR-S950 61-Key Arranger Workstation

786 voices, 408 styles, and unlimited songs.  
H88744 MSRP \$2499.00 **\$1899<sup>99</sup>**



**A PSR-E433**  
H86420 MSRP \$429.00 **\$249<sup>99</sup>**



706169

**B YPG-235**  
706169 MSRP \$519.00 **\$249<sup>99</sup>**



706175

**C YPG-535**  
706175 MSRP \$799.00 **\$499<sup>99</sup>**



H83193

**D CTK-3200**  
H83193 MSRP \$199.99 **\$129<sup>99</sup>**



H86665

**E CTK-2300**  
H86665 MSRP \$169.99 **\$99<sup>99</sup>**



H71331

**F WK-6500**  
H71331 MSRP \$349.99 **\$299<sup>99</sup>**



H71333

**G WK-7500**  
H71333 MSRP \$599.99 **\$449<sup>99</sup>**

**A. PSR-E433**

**61-key touch response keyboard with 731 natural voices.** The PSR-E433 keyboard offers features for beginners and advanced players alike. If you're just learning to play, there's the Yamaha Portable Grand and Yamaha Education Suite (Y.E.S.) to help you get started. Powerful new Styles from different musical genres can be performed with 186 different patterns and 150 arpeggio Voices. All in a design that weighs just 15 pounds.

**B. YPG-235**

**Affordable and portable grand piano sound and touch.** You get 76 piano-style keys with Graded Soft Touch action, a wide selection of Yamaha voices to play, and a 6-track song recorder. A button lets you instantly jump back to the grand piano voice during play. Add additional songs and play along using the built-in USB/MIDI port.

**C. YPG-535**

**Easy-to-own digital grand with smart features and powerful sounds!** This updated YPG series digital piano boasts upgraded 88-key, graded, soft-touch action alongside new Performance Assistance Technology for error-free performances, song-title-based setup database, 5 types of master EQ, and stylish design accents. Includes stand, power adapter, and sustain pedal. Visit us online for more info.

**D. CTK-3200**

The Casio CTK-3200 is an affordable instrument with a 61-key piano-style touch-sensitive keyboard, 400 total onboard tones, 150 rhythms and digital effects. Ideal for newer players, it features Casio's Step Up Lesson System, audio inputs for a MP3 player to make learning your favorite songs easier, USB port for MIDI implementation, and a pitch wheel for additional expression over sounds.

**E. CTK-2300**

**Quality sound in a small, affordable package.** The Casio CTK-2300 61-Key Portable Keyboard is an ideal choice for beginners who want an easy-to-use, keyboard with plenty of options. It gives you 150 rhythms patterns, 400 built-in tones, 2 sampling options, 10 reverb options, and five trigger pads, as well as USB and MIDI. Includes the Step Up Lesson system, as well as inputs for a CD or MP3 player.

**F. WK-6500**

**Sequencer and mixer functions for music creation.** A multifaceted keyboard that simplifies composing and performance, the 76-key WK-6500 features a 5-song (12,000 note), 16+1-track sequencer with a 32-channel mixer, arpeggiator, and effects. It also has 670 factory sounds, 10 user; 200 preset rhythms and auto accompaniment; piano-style keyboard and touch response; performance setup and recall; USB; SD card slot; and 6W+6W bass reflex 4-speaker system.

**G. WK-7500**

**Instantly turn your inspiration into music.** A 76-key workstation with piano-style keyboard and touch response, it gives you high-quality sounds (800 factory, 100 user); 250 preset rhythms; auto-accompaniment; a 5-song, 17-track sequencer (30,000 notes); audio recording and playback on SD/SDHC memory card; 32-channel mixer; pattern sequencer; arpeggiator; multiple digital effects; drawbar organ function with 9 sliders; USB port; 7W+7W, 2-way bass reflex speaker system; and more.

# Love Thy Neighbor

Keep the Peace, While Practicing Anytime You Wish.

by Mark Merlino, Musician's Friend Staff Writer

We all know the feeling; the best time to practice may not be the most courteous time for playing music. The next thing you know your neighbor is banging on your garage door or even worse, they've called the cops. Luckily there are options. You could move to a remote location with no neighbors, pay for long hours at expensive rehearsal halls, or simply get a JamHub.

By integrating the JamHub into your practice sessions, not only are you going to please all of your neighbors, you'll also be making the most of your busy schedule. Gone are the days of needing a loud practice PA to blast out the band's sound while you rehearse. Your entire practice will only be as loud as the acoustic instruments you use and if your drummer has an electronic drum kit, then all of the external sound is reduced to just some tapping and a few singing voices. Let's face it, not all musicians even have a garage to practice in. Imagine the ability to practice at any hour with neighbors above, below, or on all sides of your apartment.

The process is simple, all you need to do is plug your instruments and mics into the JamHub, and assign each band member their own channel number. Then all they have to do is just plug-in a pair of headphones and dial-in a personal mix of the rest of the band and you'll be able to keep practicing all night or until you get it right!



## JamHub BedRoom

The JamHub BedRoom edition gives you 15 audio channels for up to a total of five musicians, with 5 XLR and 5 TRS jacks for inputs. This is a great option for any band with 5 or less members that's looking to practice quietly without disturbing the neighbors.

620796 MSRP \$400.00 **\$299<sup>99</sup>**



## JamHub GreenRoom

JamHub's GreenRoom edition offers the ability for up to seven musicians to practice together. There's a total of seven XLR and TRS inputs, and the GreenRoom adds in both phantom power for studio condensers and a USB out so you can record your practice sessions on a computer.

620797 MSRP \$600.00 **\$499<sup>99</sup>**



## JamHub TourBus

The JamHub TourBus edition is the maxed out version and features a built-in SD RAM card slot and recording system with metronome for capturing practices on the road. It has support for up to seven musicians with a total of seven XLR and TRS inputs, USB output, and phantom power.

620798 MSRP \$850.00 **\$699<sup>99</sup>**



## Sennheiser HD 280 Pro

You're going to need headphones if you want to keep the practice quiet, and the HD 280 Pro are a good choice. Their solid construction and around ear design make for a great practice pair of cans.

242411 **\$99<sup>95</sup>**



## Audio-Technica ATH-M50

The ATH-M50's offer great isolation and comfort, making them another wise choice for practicing. They provide outstanding high-frequency response and excellent low-end response so you can hear all the details of the band. Add \$10 for white.

240569 MSRP \$199.00 **\$159<sup>00</sup>**

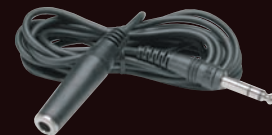

## Live Wire Headphone Extension - 10ft

Give the band some space; add a headphone extension to your JamHub rig.

330887 from **\$9<sup>99</sup>**



**CASIO**

**Privia PX-150 Digital Piano**

**Highly portable, with a topnotch piano sound.** Casio's Privia PX-150 represents a significant step in the continuing evolution of the Privia digital piano line. A combination of a new keyboard action and a powerful new sound engine provide a new level of detail, nuance and expression for a superior grand piano experience in the lightweight and stylish design that Privia is known for.

H87443 MSRP \$899.99 **\$599<sup>99</sup>**

**CDP-120 Digital Piano**

**High-quality tones and an authentic feel.** Casio's amazing 88-weighted-key, scaled hammer action digital piano features a sound engine with improved tone quality and 48-note polyphony. It's USB industry compliant, which means your computer will recognize it without having to download and install drivers. With price and performance that will satisfy students, teachers, and players alike, the CDP-120 also includes sustain pedal, AC power adapter, and music rest.

H77046 MSRP \$599.99 **\$449<sup>99</sup>**



 **YAMAHA**

**Arius YDP-C71PE**

**Natural touch and elegant appeal.** The ARIUS Series digital pianos feature graded hammer keyboards with 3-level AWM dynamic stereo sampling voices for great feel and sound, half-damper effect, song recorder, and dual-voice capability for playing 2 different instrument sounds simultaneously. Each includes a matching bench.

H80331 MSRP \$2,499.00 **\$1799<sup>99</sup>**



**P-105 Digital Piano**

**Enjoy rich sound in a simplified package.** This 88-note weighted action keyboard feels heavier in the low end and lighter in the top, just like an acoustic piano, and recreates the sound of Yamaha's famous CFIIIS concert grand piano. The newly added USB to Host port and line-level AUX outputs allow a variety of connectivity options with everything from an amplifier to an iPad. For a more complete description of the P-105, see our website.

H87344 MSRP \$999.00 **\$599<sup>99</sup>**

**WW**  
WILLIAMS



**Allegro Digital Piano**

**Realistic feel, portable package.** An excellent choice for both beginners and intermediate players, it has 88 touch-sensitive, hammer action, velocity-sensitive keys; 64-note polyphony; 8 piano keyboard sounds, including electric piano, organ, and strings; 2-track song recorder; layer, transpose, and split modes; MIDI I/O; effects; metronome; and headphone jack for silent practice.

H14022 MSRP \$499.99 **\$299<sup>99</sup>**



**P-155 Contemporary Digital Piano**

**Ultrarealistic piano sound and feel meets portability.** Yamaha handpicked a CFIIIS 9' concert grand painstakingly tuned by a master piano technician, and captured every aspect of its sound, including felt dampers resting on strings. Wood-grained cabinet adds a touch of class to any room. Includes sustain pedal and power supply.

580587 MSRP \$1,699.00 **\$999<sup>99</sup>**

# On-Stage Stands®



KS7190 Single Stand  
450246 MSRP \$43.99 **\$24<sup>95</sup>**



Standard Keyboard Stand  
450385 MSRP \$52.99 **\$29<sup>95</sup>**



Heavy-Duty Deluxe X ERGO-LOK  
Keyboard Stand  
450388 MSRP \$109.99 **\$59<sup>95</sup>**



Deluxe X 2-Tier Keyboard Stand  
450339 MSRP \$96 **\$59<sup>99</sup>**

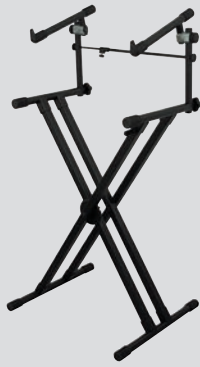

Deluxe Heavy Duty X  
2-Tier Keyboard Stand  
450342 MSRP \$126 **\$79<sup>99</sup>**



KT7800+ Keyboard Bench  
450427 MSRP \$84.99 **\$34<sup>99</sup>**



Adjustable Throne  
452071 MSRP \$145.99 **\$84<sup>95</sup>**



**YAMAHA**

L85 Piano Stand – Black  
423439 MSRP \$139.00 **\$99<sup>99</sup>**

**MUSICIAN'S GEAR**



Hydraulic Lift Piano Bench  
H89809 MSRP \$319.99 **\$249<sup>95</sup>**

**PROLINE**



ProLine PL1250 Memory Foam  
Keyboard Bench  
707018 MSRP \$89.99 **\$69<sup>99</sup>**



**MUSICIAN'S GEAR**  
61-Key  
Keyboard Gig Bag  
545128 MSRP \$69.95 **\$39<sup>99</sup>**



61-and 76-Key Stretchy Keyboard Cover  
545190 MSRP \$29.99 **\$19<sup>99</sup>**



76-Key Keyboard Gig Bag  
545129 MSRP \$79.95 **\$44<sup>99</sup>**



88-Key  
Keyboard Gig Bag  
545130  
MSRP \$89.95 **\$49<sup>99</sup>**

EXCLUSIVE



Silver Series 1/4" Straight Instrument Cable  
339028 from \$10<sup>99</sup>

MOGAMI®



Gold High-Definition Neutrik 1/4" Straight Instrument Cable  
333170 from \$49<sup>95</sup>

MUSICIAN'S GEAR



Pedal Coupler Cable Angled Black  
330244 from \$3<sup>00</sup>

LIVE WIRE.



1/4" Angle-1/4" Angle 6" Patch Cable 3-Pack  
H77532 MSRP \$12.60 \$6<sup>99</sup>



Advantage Series 1/4" Straight Instrument Cable 3 Foot  
330470 MSRP \$9.99 \$7<sup>99</sup>



Advantage Series 1/4" Angled - Straight Instrument Cable 1 Foot  
330471 MSRP \$15.99 \$9<sup>99</sup>



Braided Instrument Cable 1/4"  
361705 from \$3<sup>99</sup>



Custom Shop Performance Series Right Angle Instrument Cable  
H74843 from \$29<sup>99</sup>



Custom Shop Instrument Cable  
H90005 from \$17<sup>99</sup>

Fender



Performance Series Instrument Cable  
H74844 from \$9<sup>99</sup>

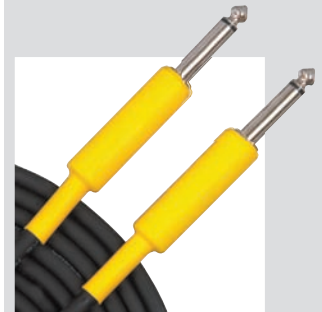

Musician's Gear 1/4" Straight Instrument Cable 20 Foot  
333210 \$8<sup>99</sup>

MONSTER CABLE®



S-100 1/4" Straight Instrument Cable  
331638 from \$12<sup>95</sup>



Monster Rock 1/4" Straight Instrument Cable 8 Inches  
331650 from \$24<sup>95</sup>



Monster Rock 1/4" Straight - Angled Instrument Cable  
331652 from \$39<sup>95</sup>



Tweed Right Angle Instrument Cable Gold 10 Feet  
584720 from \$11<sup>99</sup>

PLANET WAVES™



Circuit Breaker 1/4" Straight Instrument Cable  
335277 from \$39<sup>99</sup>

DiMarzio®



Instrument Cable  
332100 from \$24<sup>99</sup>



Jumper Cable Pedal Coupler  
332101 from \$15<sup>99</sup>

RapcoHorizon COMPANY



Standard Guitar Cable  
336010 from \$7<sup>99</sup>

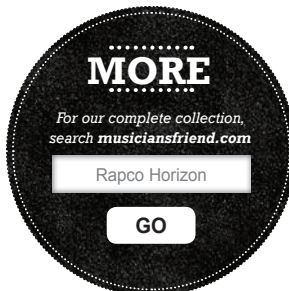

For our complete collection, search [musiciansfriend.com](http://musiciansfriend.com)

Rapco Horizon

GO



Instrument Cable 20 Feet 4-Pack  
582062 MSRP \$35.96 \$19<sup>99</sup>

**MUSICIAN'S GEAR**

**Folding Music Stand**  
451034 MSRP \$24.99 **\$10<sup>99</sup>**

**Deluxe Conductor Music Stand**  
450348 MSRP \$61.05 **\$26<sup>99</sup>**

**Deluxe Music Stand 6-Pack**  
581697 MSRP \$366.30 **\$119<sup>94</sup>**

**LED Lamp For Piano/Desk Black**  
Available in black (shown), silver matte or chrome finish  
H92126 MSRP \$139.99 **\$99<sup>99</sup>**

**PROLINE**

**Conductor Sheet Music Stand 6-Pack**  
502533 MSRP \$359.94 **\$139<sup>92</sup>**

**PL53 Tabletop Sheet Music Stand Black**  
581187 MSRP \$39.99 **\$19<sup>99</sup>**

**MANHASSET**

**M48 Carton of 6 Music Stands**  
450188 MSRP \$407.16 **\$189<sup>00</sup>**

**Music Stand Storage Cart (Holds 25)**  
H65650 MSRP \$716.01 **\$399<sup>99</sup>**

**M48 Symphony Music Stand**  
450172 MSRP \$79.71 **\$39<sup>99</sup>**

**HAMILTON**

**KB95/E Music Stand with Clutch**  
450244 MSRP \$66.99 **\$34<sup>99</sup>**

**PEAK MUSIC STANDS**

**Portable Music Stand**  
459529 MSRP \$51.5 **\$29<sup>99</sup>**

**MIGHTY BRIGHT**

**Encore LED Light with Case**  
H83112 MSRP \$44.99 **\$35<sup>99</sup>**

**HammerHead Music Light**  
H83111 MSRP \$24.99 **\$19<sup>99</sup>**

38 More models. More colors. More styles. Visit [musiciansfriend.com](http://musiciansfriend.com)



### 15 Top Hits For Easy Piano 2012 Edition (Book)

Easy arrangements of more than a dozen recent hits: Brighter Than the Sun, Firework, Glad You Came, A Thousand Years, We Are Young, What Makes You Beautiful, many more.

H92632 MSRP \$14.99 **\$13<sup>49</sup>**



### The Grammy Awards Best Female Pop Vocal Performance 2000-2009 - (Book/CD)

Whether you're a karaoke singer or preparing for an audition, the Pro Vocal series is for you: Ain't No Other Man, Beautiful, Chasing Pavements, Don't Know Why, More...

H94286 MSRP \$14.99 **\$13<sup>64</sup>**



### The Grammy Awards Best Male Pop Vocal Performance 2000-2009 (Book/CD)

Whether you're a karaoke singer or preparing for an audition, the Pro Vocal series is for you. The book contains lyrics, melody, and chord symbols for eight classics: Cry Me a River, Daughters, From the Bottom of My Heart, and more.

H94322 MSRP \$14.99 **\$13<sup>64</sup>**



### MAROON 5 OVEREXPOSED (Book)

Featuring the hit singles "Pay Phone" and "One More Night." This matching folio includes arrangements of these two titles along with ten others.

H90306 MSRP \$16.99 **\$15<sup>29</sup>**



### Piano Bar Favorites (Book)

Here are 45 favorites guaranteed to get the party started! Includes: All You Need Is Love, Bad Day, Bohemian Rhapsody, Free Fallin', Hot Hot Hot, Walking on Sunshine, and dozens of others. H90271 MSRP \$17.99 **\$16<sup>19</sup>**

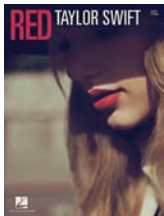

### Taylor Swift - Red Songbook

16 tracks from Swift's record-breaking blockbuster album, all presented in easy piano notation: All Too Well \* Begin Again \* Everything Has Changed \* Holy Ground I Almost Do \* and much more. H92096 MSRP \$15.99 **\$14<sup>39</sup>**



### Scott Healy - Learn to Play Piano, A Complete Course (2 DVD Set)

The music of Super Mario Bros.™ was the soundtrack of the golden age of video games and now musicians can learn the officially licensed versions.

H78657 MSRP \$19.99 **\$17<sup>99</sup>**



### Scott Healy - Learn to Play Piano, A Complete Course - 2 DVD Set

This program, designed by Scott Healy of Conans Basic Cable Band, teaches all the basics needed to start playing quickly.

H72835 MSRP \$24.99 **\$19<sup>99</sup>**



### Adele Piano Play-Along Vol. 111 (Book/CD)

The music in this book matches the recorded orchestrations. The book even includes a separate vocal staff, plus guitar frames, so you or your friends can also sing or strum along.

H86862 MSRP \$14.99 **\$13<sup>49</sup>**

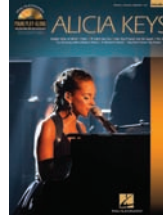

### Alicia Keys - Piano Play-Along Volume 117 (Book/CD)

Comes with a CD of orchestrated arrangements with two tracks for each - a full performance for listening, plus a separate backing track which lets you be the soloist!

H80386 MSRP \$14.99 **\$13<sup>49</sup>**



### The Lumineers for Piano/Vocal/Guitar (Book)

All 11 songs off the eponymous debut by the Denver folk-rock trio that's generating giant buzz. Includes the smash-hit single "Ho Hey" and: Big Parade, Charlie Boy, Classy Girls, Dead Sea, Flapper Girl, Flowers in Your Hair, Morning Song, Slow It Down, Stubborn Love, Submarines.

H93761 MSRP \$16.99 **\$15<sup>29</sup>**



### Top Christian Hits of 2012-2013 for Piano/Vocal/Guitar PVG (Book)

20 of the biggest chart hits, including: All This Time, Carry Me to the Cross, Center of It, Forgiveness, Good to Be Alive, Losing, Me Without You, My Hope Is in You, Redeemed, Waiting for Tomorrow, Where I Belong, White Flag, and more.

H94260 MSRP \$16.99 **\$15<sup>46</sup>**



### Contemporary Coffeehouse Songs for Piano/Vocal/Guitar (Book)

A collection of nearly 50 songs from today's top singer/songwriters, including: Babylon, Come On Get Higher, Fallin' for You, Hallelujah, I Will Follow You into the Dark, Lucky, Meet Virginia, Put Your Records On, Wonderwall, and more. H94254 MSRP \$19.99 **\$18<sup>19</sup>**



### Adele 21 for Easy Piano (Book)

The Adele 21 For Easy Piano songbook matches the British singer's sophomore CD, with easy piano arrangements of the smash hits, "Rolling in the Deep," "Someone like You," and more.

H79438 **\$14<sup>99</sup>**



### TEACH YOURSELF TO PLAY PIANO METHOD DLX (CD-ROM)

Teach Yourself To Play Piano Deluxe Edition is a step-by-step approach on CD-ROM for beginners of all ages to learn keyboard.

950137 MSRP \$29.95 **\$26<sup>96</sup>**



### Play Keyboard Today! (Book/CD/DVD Pack)

Teaches absolute beginners how to play the piano at your own pace and in your own style. CD includes audio instruction as well as accompaniment tracks. 56 pages. Also includes a DVD with video demonstrations.

942401 **\$19<sup>95</sup>**

**PROLINE®**



**A D12 VR**  
H90480 MSRP \$649.00 **\$499<sup>00</sup>**

**SHURE**



Mic sold separately as 270102

**B SM57, Stand & Cable Package**  
H91372 MSRP \$243.94 **\$109<sup>00</sup>**  
**SM57 Instrument/Vocal Mic**  
270102 MSRP \$124.00 **\$99<sup>00</sup>**

**A. D12 VR**

**Revisiting a classic.** The D12 VR is a reissue of one of the most famous dynamic mics in history. In the spirit of the D12, AKG has released the D12 VR with its extremely thin 3mm diaphragm and an optimized bass chamber that further enhances bass response. Use the D12 VR in its standard dynamic form, or engage phantom power to access one of three active-filter presets for additional tone shaping ability.

**B. SM57, STAND & CABLE PACKAGE**

**Mic, cable, and stand in one complete package.** This microphone package features the legendary Shure SM57 instrument mic, together with a 20' long Gear One XLR mic cable and a Musician's Gear Tripod Mic Stand with fixed boom so you can position your new mic just about anywhere you'd like.

**C. ENCORE 100i**

**A studio-grade dynamic mic designed for the stage.** The enCORE 100i features a special dynamic capsule with a diaphragm custom-tuned to provide a tighter polar pattern, that makes this mic an excellent choice for instruments and other sources requiring high isolation. Its unique grille protects against wayward drumsticks and other strikes.



Microphones



**C enCORE 100i**  
430562 **\$89<sup>89</sup>**



**D i5 Instrument Mic**  
270644 MSRP \$150.00 **\$99<sup>99</sup>**

**SENNHEISER**



Mic sold separately as 276668

**E e 609 Silver, Stand and Cable Package**  
486216 MSRP \$283.94 **\$129<sup>99</sup>**  
**e 609 Silver**  
276668 **\$109<sup>95</sup>**

**D. i5 INSTRUMENT MIC**

**Versatile and rugged with amazing sound.** Cardioid-pattern dynamic mic has a smooth, uniform frequency response with 140dB SPL handling making it versatile enough to mic everything from vocals to guitar amps and sound great doing it. A durable cast zinc alloy body and dent-resistant grille make it lightweight and roadworthy. Includes a heavy-duty mic clip and carrying pouch.

**E. e 609 SILVER, STAND & CABLE PACKAGE**

**Stand, cable and dynamic guitar mic in one package.** The Sennheiser e 609 Silver Dynamic Guitar Mic makes getting killer electric guitar sounds in your project studio or onstage a cinch. The e609 Silver is based on the legendary MD 409 mic, a longtime secret weapon of engineers for recording rock guitar with plenty of growl and punch.

**F. PREMIUM 7-PIECE DRUM MIC PACK**

**Step up to CAD's best drum mic pack!** Extended frequency response, superior sensitivity, and faster transient response. Includes a rugged KBM412 dynamic kick mic, 4 TSM411 neodymium dynamic mics, 2 ICM417 electret condenser mics, and 4 DMC-1 mic clips.



**F Premium 7-Piece Drum Mic Pack**  
271264 MSRP \$399.00 **\$249<sup>99</sup>**



**G MD421 II Mic**  
270820 **\$379<sup>95</sup>**

**G. MD421 II MIC**

**A studio standard.** Talk to just about any seasoned FOH or recording engineer about their drum-miking preferences for toms and percussion and the MD421 II will invariably come up. The 5-position bass control enhances its all-around qualities. With very effective feedback rejection and a highly directional cardioid pickup pattern, placement is a cinch. Rugged construction.



**SHURE**

**\$20 MAIL-IN REBATE**



- A Beta 57A**  
Instrument Mic  
270121 MSRP \$174.00 **\$139<sup>00</sup> Before Rebate**
- Beta 87A**  
Vocal Mic  
270168 MSRP \$311.00 **\$249<sup>00</sup> Before Rebate**
- Beta 58A**  
Vocal Mic  
270120 MSRP \$199.00 **\$159<sup>00</sup> Before Rebate**
- Beta 52A**  
Kick Drum Mic  
270267 MSRP \$236.00 **\$189<sup>00</sup> Before Rebate**
- Beta 87C**  
Vocal Mic  
271700 MSRP \$311.00 **\$249<sup>00</sup> Before Rebate**

**A. BETA SERIES**

**Rugged and road-ready mics.** The Beta Series from Shure are built to withstand the road and the abuse that comes with a traveling musician. These warm, natural-sounding mics provide maximum isolation and high gain before feedback, which makes them great for any stage. These mics are engineered to reproduce fine details in the most demanding environments.

**B. e 835**

**Outstanding combination of affordability, build quality, and performance.** Designed for stage use, it gives vocals a solid sound with good projection. A gentle presence boost provides clarity without sounding unnatural. Minimal proximity effect means good overall tonal balance without over-accentuating low frequencies as you move closer to the capsule.

**C. e 935**

**Professionally developed to cut through high onstage sound levels.** Rugged metal body with advanced shock mount design takes what the road dishes out for years of reliable service. Consistent on-/off-axis response minimizes feedback problems and makes performance easier. Hum-compensating coil reduces noise and allows for longer leads. Made in Germany. Includes carry pouch and mic clip.

**SENNHEISER**



- B e 835**  
270825 **\$99<sup>95</sup>**
- C e 935**  
276672 **\$169<sup>95</sup>**

**SHURE**



- E SM58**  
270101 MSRP \$124.00 **\$99<sup>00</sup>**
- SM58, Stand & Cable Package**  
H91368 MSRP \$243.94 **\$109<sup>00</sup>**

**D. D 5**

**A live performance vocal mic designed for singers in high-volume bands.** The supercardioid polar pattern ensures maximum gain before feedback and a crisp sound that cuts through every mix. The dual shock mount eliminates any kind of mechanical noise for trouble-free live use.

**E. SM58**

**The world's most popular vocal mic.** This mic has not only helped define the sound of rock vocals on stage, it's also been used as a hammer to build stages and gone on to perform flawlessly later at the gig. Using a club's house system? You'll likely be singing through an SM58. And in the studio? Daniel Lanois often uses the SM58 or Beta 58 on Bono's vocals.

**Blue**  
Microphones



- F enCORE 100**  
583063 **\$99<sup>00</sup>**

**F. ENCORE 100**

**Studio-grade performance for the stage.** Its proprietary capsule is specially tuned by Blue's engineers to deliver amazing detail and clarity to natural vocals with balanced highs. Cardioid polar pattern. High 147dB SPL handling. 50Hz-15kHz frequency response. Stage-ready construction with heavy-gauge barrel.

**AKG**  
by HARMAN



- D D 5**  
270475 MSRP \$139.00 **\$99<sup>00</sup>**

**audio-technica**



- G M4000S 3-Pack Mic and Bag Kit**  
483253 MSRP \$659.89 **\$79<sup>99</sup>**

**G. M4000S 3-PACK MIC AND BAG KIT**  
**Mics, cables, and carrying bag at an unbeatable price.** The M4000S 3-Pack Mic and Bag Kit comes with 3 Audio-Technica M4000S microphones, 3 20' microphone cables, and a handy carrying case. The Audio-Technica M4000S hand-held dynamic microphone has professional features and is now available in a 3-pack at a ridiculously affordable price. Its frequency response is tailored for crystal-clear vocal reproduction.

## PERCEPTION



**\$50 INSTANT REBATE**



Specifically tailored to your needs, from single-channel applications and individual configurations to multichannel systems, AKG Perception Wireless systems deliver brilliant sound and are surprisingly easy to use.

### Perception Wireless Vocal Set Band A

Includes the SR 45 receiver, HT 45 handheld transmitter, universal power supply with US/UK/EU adapter, SA 45 stand adapter, and one AA-size dry battery.

H68228 MSRP \$359.00 **\$249<sup>99</sup>** Before Rebate **\$199<sup>99</sup>** After Rebate

### Perception Wireless Instrumental Set Band A

Includes the SR 45 receiver, PT 45 pocket transmitter, MKG L cable with 1/4" jack and mini XLR connector, universal power supply with US/UK/EU adapter, and one AA-size dry battery.

H68227 MSRP \$359.00 **\$249<sup>99</sup>** Before Rebate **\$199<sup>99</sup>** After Rebate

### Perception Wireless Sports Set Band A

Includes the SR 45 receiver, PT 45 body-pack transmitter, universal power supply with US/UK/EU adapter, C 544 L headset mic, and one AA-size dry battery.

H68229 MSRP \$389.00 **\$299<sup>99</sup>** Before Rebate **\$249<sup>99</sup>** After Rebate

### Perception Wireless Presenter Set Band A

Includes the SR 45 receiver, PT 45 body-pack transmitter, universal power supply with US/UK/EU adapter, CK 99 L lavalier mic, and one AA-size dry battery.

H68230 MSRP \$389.00 **\$299<sup>99</sup>** Before Rebate **\$249<sup>99</sup>** After Rebate

## SENNHEISER

### XSW SERIES



The XSW set of wireless microphones from Sennheiser deliver the handsfree performance that is required from a digital wireless system. An affordable set with exceptional sound quality, the XSW Series sets feature an EM10 true diversity receiver, 24 MHz-switching bandwidth, 960 available frequencies, and much more. See our website for more details.

#### XSW 35 Handheld Set

With SKM 35 handheld mic.

H79725 **\$399<sup>95</sup>**

#### XSW 72 Instrument Set

With SK 20 bodypack and CI 1 instrument cable.

H79726 **\$399<sup>95</sup>**

#### XSW 12 Presentation Set

With SK 20 bodypack and ME 2-2 clip-on mic.

H79729 **\$399<sup>95</sup>**

#### XSW 52 Headmic Set

With SK 20 bodypack and ME 3 headset mic.

H79727 **\$449<sup>95</sup>**

#### XSW 65 Vocal Set

With SKM 65 handheld mic.

H79728 **\$449<sup>95</sup>**



### Relay G30 Digital Wireless System

Professional dependability, and refreshing simplicity.

It provides a signal so pure that guitars produce beautiful high-end sparkle and basses explode with thunderous low-end punch at distances up to 98'. Clarity rivals that of the highest-quality guitar cables. Traditional wireless systems compromise their sound by rolling off crucial high- and low-end frequencies and compressing their signals. Relay G30 offers full bandwidth and zero compression. Superior 118dB dynamic range. 8-hour battery life.

502387 MSRP \$419.99 **\$299<sup>99</sup>**

### Relay G50 Digital Wireless System

Same as 502387 with a metal stompbox-style receiver, 200-foot range, 120dB dynamic range, tuner pass-thru, and LCD displays.

502389 MSRP \$559.99 **\$399<sup>99</sup>**

### Relay G55 Digital Wireless Guitar System

Same as 502387 with twice as many compatible channels, triple the line-of-sight distance reliability, XLR output, a more detailed LCD display, and other pro features.

H90655 MSRP \$629.99 **\$449<sup>99</sup>**

### Relay G90 Rackmount Digital Wireless Guitar System

Same as 502387 with a metal 1U rackmount receiver, 300-foot range, 120dB dynamic range, XLR out and tuner pass-thru, and LCD displays.

502388 MSRP \$839.99 **\$599<sup>99</sup>**



## SYSTEM 10

System 10 is a high-fidelity digital wireless system designed for easy setup with clear, natural sound. System 10 gives musicians and presenters freedom onstage, with a 2.4GHz range that's far from TV or DTV interference. Each configuration includes the ATW-R1100 receiver and various transmitter options. Additional mic and cable options are available online.

### System 10 Wireless Handheld System

ATW-T1002 handheld mic.  
H90605 MSRP \$524.95 **\$299<sup>95</sup>**

### System 10 Wireless Instrument System

GcW instrument cable.  
H90607 MSRP \$524.95 **\$299<sup>95</sup>**

### System 10 Wireless Lavalier System

MT830cW lavalier mic.  
H90603 MSRP \$614.95 **\$349<sup>95</sup>**

### System 10 Wireless Headset System

8HEcW headworn mic.  
H90602 MSRP \$614.95 **\$349<sup>95</sup>**



# SHURE®

## GLX-D DIGITAL WIRELESS

The GLX-D Series wireless is Shure's latest design in digital wireless. Digital wireless has several advantages over conventional wireless systems, most notably that the signal doesn't undergo a compression process at the transmitter followed by an expansion process at the receiver. Digital wireless decreases noise and preserves greater signal integrity. The GLX-D product line brings first-quality digital wireless into a price range that is within the reach of working musicians. Available in handheld, guitar, lavalier and headset configurations, GLX-D digital wireless is positioned to revolutionize live performance.

**GLXD24/SM58 Handheld Digital Wireless System with SM58 Capsule**  
H96356 MSRP \$624.00 **\$499<sup>99</sup>**

**GLXD24/B58 Handheld Digital Wireless System with Beta Capsule**  
H96346 MSRP \$689.00 **\$549<sup>99</sup>**

**GLXD/B87A Handheld Digital Wireless System with Beta 87A Capsule**  
H96354 MSRP \$736.00 **\$589<sup>99</sup>**

**GLXD14 Instrument Digital Wireless System**  
H96351 MSRP \$561.00 **\$449<sup>99</sup>**

**GLXD14/93 Lavalier Digital Wireless System with Omni Lav Mic**  
H96350 MSRP \$649.00 **\$519<sup>99</sup>**

**GLXD14/PG30 Headset Digital Wireless System**  
H96345 MSRP \$649.00 **\$519<sup>99</sup>**



**YOUR HOURS BEHIND THE BOARD  
DESERVE OUR YEARS BEHIND THE SOUND.**



**SHURE PROFESSIONAL HEADPHONES** When sound is both a passion and profession, there's no room for compromise. Whether mixing, mastering or tracking, Shure offers a variety of models that deliver high-performance audio and rugged durability. After all, we've spent over 85 years focused on precision engineering. So you can, too.

[www.shure.com/americas](http://www.shure.com/americas)

© 2012 Shure Incorporated

**SHURE**<sup>®</sup>  
LEGENDARY  
PERFORMANCE<sup>™</sup>

# SHURE®

## BLX SERIES

Shure has long been at the forefront of wireless technology for microphones and instruments. The BLX family of wireless products is their most recent offering in this ever-expanding product area, and provides an affordable, high-quality solution to wireless music, business and other live presentations. BLX Wireless Systems deliver a performance range of up to 300 feet, with up to 14 hours of battery life from two AA batteries. Systems are available in a wide offering of bodypack and handheld configurations with multiple handheld, lavalier, instrument, and headset microphone choices. The BLX4R uses Shure's durable half-rack chassis with removable antennas and includes everything you need to install it in an equipment rack.



### BLX14R Wireless Guitar System with Rackmountable Receiver

H95324 MSRP \$474.00 **\$379<sup>79</sup>**

### BLX24R/SM58 Handheld Wireless System with SM58 Capsule and Rackmountable Receiver

H95343 MSRP \$499.00 **\$399<sup>49</sup>**

### BLX24R/B58 Handheld Wireless System with Beta 58A Capsule and Rackmountable Receiver

H95339 MSRP \$561.00 **\$449<sup>00</sup>**

### BLX14R/W93 BLX Wireless Lavalier System with Omnidirectional Mini Lavalier Mic and Rackmountable Receiver

H95338 MSRP \$536.00 **\$429<sup>79</sup>**

### BLX14R/W85 Wireless Lavalier System with WL185 Cardioid Lavalier Mic and Rackmountable Receiver

H95344 MSRP \$561.00 **\$449<sup>00</sup>**

### BLX14R/MX53 Wireless Headset System with MX153 Headset Mic and Rackmountable Receiver

H95329 MSRP \$686.00 **\$549<sup>49</sup>**

### BLX24/SM58 Handheld Wireless System with SM58 Capsule

H95323 MSRP \$436.00 **\$349<sup>49</sup>**

### BLX24/B58 Handheld Wireless System with Beta 58A Capsule

H95331 MSRP \$499.00 **\$399<sup>99</sup>**

### BLX24/PG58 BLX B58 Handheld Wireless System with PG58 Capsule

H95327 MSRP \$374.00 **\$299<sup>99</sup>**



### BLX14 BLX Instrument Wireless System

H95336 MSRP \$374.00 **\$299<sup>99</sup>**

### BLX14/PG85 BLX Wireless Lavalier System

H95325 MSRP \$374.00 **\$299<sup>99</sup>**

### BLX14/PG30 BLX Wireless Headset System

H95346 MSRP \$374.00 **\$299<sup>99</sup>**

### BLX14/B98 BLX Wireless Horn System with Cardioid Condenser Mic

H95330 MSRP \$561.00 **\$449<sup>99</sup>**



**MUSICIAN'S GEAR**



**Die-Cast Mic Stand Black**  
451053 MSRP \$39.99 **\$15<sup>99</sup>**



**Tripod Mic Stand with Fixed Boom Black**  
451051 MSRP \$69.99 **\$19<sup>99</sup>**



**Tripod Mic Stand with Fixed Boom Black 2-Pack**  
582353 MSRP \$139.98 **\$29<sup>98</sup>**

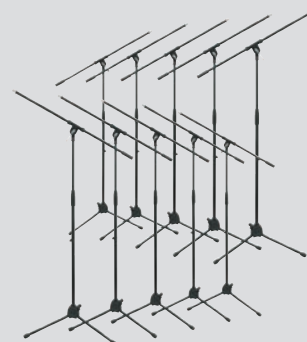

**Tripod Mic Stand with Fixed Boom 10-Pack**  
450464 MSRP \$699.90 **\$99<sup>90</sup>**



**Mic Stand Package**  
452062 MSRP \$464.65 **\$129<sup>99</sup>**



**Heavy-Duty Tripod Base Mic Stand**  
H70407 MSRP \$68.99 **\$39<sup>95</sup>**



**72010 Tripod Mic Stand with Boom**  
452061 MSRP \$53.99 **\$24<sup>95</sup>**



**Heavy-Duty Tele-Boom Mic Stand**  
712990 MSRP \$93.99 **\$52<sup>95</sup>**



**Quick Release Tripod Microphone Stand**  
459545 MSRP \$103.99 **\$49<sup>99</sup>**



**Tripod Mic Boom Stand**  
451141 MSRP \$89.99 **\$69<sup>99</sup>**

**PROLINE**



**ProLine MS112 Desk Boom Mic Stand**  
454312 MSRP \$43.49 **\$29<sup>99</sup>**



**MS220 Tripod Boom Microphone Stand Chrome**  
454314 MSRP \$74.49 **\$42<sup>99</sup>**



**MS220 Tripod Boom Microphone Stand Black**  
454314 MSRP \$73.99 **\$39<sup>99</sup>**

**MUSICIAN'S GEAR**



Lo-Z Microphone Cable - 6 foot  
338001 MSRP \$7.95 **\$4<sup>99</sup>**



Tweed Lo-Z Woven Mic Cable  
330076 MSRP \$22.95 **\$13<sup>99</sup>**



XLR Microphone Cable - 20 Foot  
331174 MSRP \$29.99 **\$14<sup>99</sup>**



Lo-Z Mic Cable - 20 Feet 4-Pack  
582060 MSRP \$119.96 **\$29<sup>96</sup>**



Lo-Z Microphone Cable - 20 Foot 10-Pack  
338006 MSRP \$299.99 **\$49<sup>99</sup>**

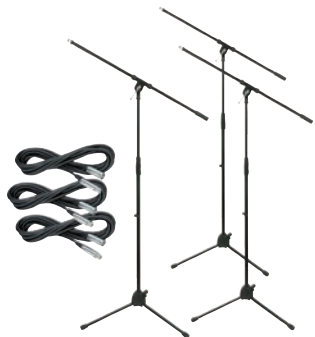

Tripod Mic Stand with 20 Foot Mic Cable 3-Pack  
H77700 MSRP \$359.82 **\$49<sup>99</sup>**

**GEAR ONE™**

MV1000 with Cable and Stand  
H78318

MSRP \$319.93 **\$49<sup>99</sup>**



**PRO CO**

StageMASTER Microphone Cable  
H84145 from **\$7<sup>99</sup>**



**EXCLUSIVE**



Silver Series XLR Microphone Cable  
H89880 from **\$16<sup>99</sup>**

**MOGAMI®**



Gold Neglex Quad Mic Cable for Studio Neutrik XLR  
338010 from **\$39<sup>95</sup>**



Gold Stage Mic Cable with Neutrik XLR Connectors  
338011 from **\$69<sup>95</sup>**



**Blue** Microphones

Dual Microphone Cable Blue 20 Feet  
712786 **\$29<sup>99</sup>**



**MONSTER CABLE®**

S-100 XLR Microphone Cable  
331643 from **\$19<sup>95</sup>**

**PLANET WAVES™**  
MUSIC UTILITY COMPANY



Classic Microphone Cable Lo-Z  
339121 from **\$28<sup>99</sup>**



Performer 500 Microphone Cable  
331680 from **\$34<sup>95</sup>**

**RapcoHorizon**  
COMPANY



Standard Lo-Z Microphone Cable  
336360 from **\$10<sup>99</sup>**

**Atlas Sound**



Atlas Signal Mic Cable  
H65847 MSRP \$24.95 **\$20<sup>50</sup>**

**LIVE WIRE ADVANTAGE**



Advantage Standard EXM Series Microphone Cable - 3 Foot  
331095 from **\$14<sup>99</sup>**



Advantage Deluxe M Series Microphone Cable - 5 Foot  
331126 from **\$20<sup>99</sup>**

**MORE**

For our complete collection, search [musiciansfriend.com](http://musiciansfriend.com)

Mogami

GO



# Share and Share Alike

## Putting the band back in the garage

by John McVarish, Musician's Friend Staff Writer

Imagine your group or family's musical equipment, always plugged in and ready to jam. Anytime inspiration strikes or the team is available, you just turn on and rock out. That sounds nice, but most of us can't devote a whole room in our homes for band rehearsals. If you have a garage though, there might be an opportunity to arrange a convenient practice space there. The problem is that the garage will probably already be full of everyone's stuff, if not a car or two.

One of the pleasures of being a musician is the pursuit of the perfect sound and setup. When you're onstage, you have your carefully chosen live rig and hopefully a decent house PA. If you handle your own sound reinforcement, then you've certainly put a lot of research and effort into finding the right features, convenience and value.

Shopping for rehearsal space gear can be just as fun, albeit with a different list of requirements. What you choose depends on your budget, how much space you have, the noise-level you should respect and whether you're able to leave everything set up. Fortunately, technology is on our side. The trend in musical equipment is to squeeze more and more features into ever-smaller and even less expensive packages.

As we say goodbye to the days of tall stacks, high volumes and noise complaints, let's consider some new and impressive gear that will make sharing the garage to make music an achievable dream.

### To E-Kit Or Not To E-Kit

#### Ludwig Breakbeats by Questlove 4-Piece Shell Pack

Here's a garage-friendly kit designed by Ahmir "Questlove" Thompson that stores easily and delivers a rough-and-ready sound despite its sub-compact size. Created for sonic punch and portability it includes 4 pieces: a 16 x 14" bass drum, a 13 x 13" floor tom, a 10 x 7" tom and a matching 14 x 5" snare, all in Azure Sparkle that'll brighten your windowless garage. It comes with a bass drum lift that gets the kit to full-size playable height or that can be left off for younger players.

H91063 . . .MSRP \$619.00 **\$399<sup>99</sup>**

#### Roland V-Drums TD-4-KP Portable Electronic Drum Set

Here's the ultimate e-kit for sharing space in the garage. It's ultracompact and collapses quickly to take up barely any room. The TD-4 sound module is loaded with a wide range of expressive, editable sounds, and comes with 8 integrated pads that provide a satisfying feel and natural playability. These include kick, snare, toms x3, hi-hat, crash and ride cymbals. The kit also comes with a FD-8 Hi-Hat Controller. Just add a kick pedal and monitor.

H95651 . . .MSRP \$1,099.00 **\$799<sup>00</sup>**



#### Simmons DA50 Electronic Drum Set Monitor

This 50-watt workhorse is the right size for rehearsing with electronic drums in the garage. It's efficiently angled to direct the sound where you want it and has a 10" woofer and a separate high-frequency tweeter to reproduce full percussive dynamics. Its 1/8" MP3 and 1/4" aux inputs with independent volume control allow you to mix in prerecorded backing tracks. There's even a headphone jack for silent practice.

490070 . . .MSRP \$399.99 **\$199<sup>99</sup>**



## Shell-size Bass and Guitar Amps

### TC Electronic BG250 Combo

A 15" speaker and 250 watts of class D power might seem like overkill for the garage, but its efficient design and cool features make this bass combo hard to resist. The preamp includes an integrated tuner, TubeDrive, intelligent Bass Tone controls and balanced XLR out. An amazing effects section called TonePrint lets you swap effects at any time. Simply connect the amp to a computer via a USB cable or beam the effect from your smartphone straight into this combo using the TonePrint iOS and Android app.

H80770 . . .MSRP \$599.00 **\$399<sup>99</sup>**

### Peavey Vypyr VIP 1 20W 1x8 Guitar Modeling Combo Amp

The new Peavey VYPYR VIP series provides amplification for a variety of instruments from acoustic and electric guitars to basses. Using a combination of powerful 32-bit, floating point SHARC processors and patented TransTube analog circuitry, this garage-sized titan creates some of the best sounding modeling amps available. The USB bi-directional data and audio port provides an easy way to record, connect to VYPYR software, store presets, get lessons and practice to backing tracks.

H92675 . . .MSRP \$199.99 **\$129<sup>99</sup>**

### Fender Blues Junior™ NOS Combo

The Blues Jr. pushed through a 12" Jensen speaker. A warm-toned favorite, this version of the vintage 15W all-tube amp features a 12" Jensen speaker and that sound that comes from a pair of EL84 Groove Tube output tubes and three 12AX7 preamp tubes. Add renowned Fender reverb, flexible controls and footswitchable (with optional switch) FAT circuit for golden tones, and you're in the blues business. Lacquer tweed with pinstripe grille cloth.

483711. . .MSRP \$789.99 **\$599<sup>99</sup>**



## Where Are The Garage Keys?

### Roland KC-60 Keyboard Amp

Keyboards require a full-frequency amp. This garage-friendly model is the most compact in Roland's KC series, yet still has enough power to compete with a small drum kit. Its 40W power section drives a 10" speaker with 3 separate channels that include 1/4" line, XLR mic, and aux inputs so you can easily mix different sound sources. Rotary controls adjust channel and headphone outputs plus low and hi EQ. Also, there's even a subwoofer output that offers big bottom-end potential if needed.

480025. . .MSRP \$444.00 **\$349<sup>00</sup>**



## Space-Saving P.A.

### Mackie DL1608 iPad Mixer

Mix from anywhere in the venue. The DL1608 redefines live mixing by combining a full-featured digital mixer with the ease and mobility of the iPad. With 16 boutique-quality Onyx mic preamps, and 24-bit Cirrus Logic AD/DA converters, you're guaranteed professional quality sound. Seamless wired to wireless iPad control means you can mix from anywhere in the venue, and with support for up to 10 iPads, each band member can control their own monitor mix.

H80461 . . .MSRP \$1,249.99 **\$999<sup>99</sup>**

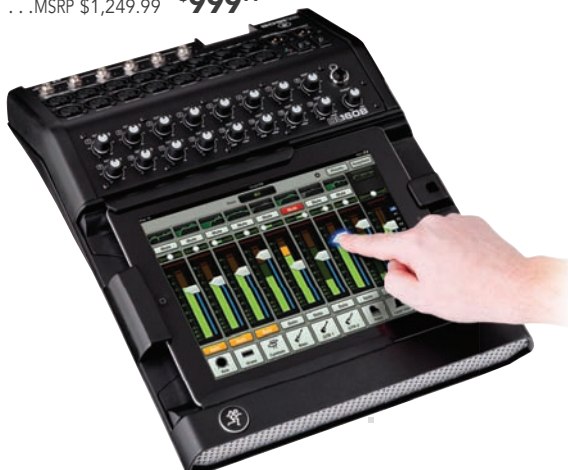

### Mackie SRM150 Active Speaker

Designed to top a mic stand or boom. The SRM150 Compact Active PA Speaker is ideal for a wide variety of applications. Don't be fooled by its small size, it's a powerful 3-channel PA system that is ultracompact, versatile, expandable, and affordable.

485389. . .MSRP \$329.99 **\$249<sup>99</sup>**



### Yamaha STAGEPAS 300 Portable PA System

Pack your PA, amp, and guitars in your back seat without a shoehorn. Ultracompact design incorporates 2 - 2-way loudspeakers, a 6/8-channel (4 mono, 2 stereo) mixer, and dual 150W amplifiers in a sound system that one person can handle. Each speaker contains an 8" woofer, 1" compression driver, and its own amp. The mixer features balanced XLR and 1/4" jacks, mic/line switches, stereo RCA jacks, 2-band channel EQ, and reverb. Stereo-out and monitor connections let you set your monitor level and connect to an external PA. The entire system packs neatly into the speaker enclosures. Includes power and speaker cables.

480818. . .MSRP \$789.00 **\$499<sup>99</sup>**



While Supplies Last



## The Perfect Fit - Design - Solution

PreSonus & Behringer  
Doghouse Cases  
Also Available With Gator's  
360 ARM!

- Flight case custom fit for the mixer (Behringer X-32 shown below)
- Doghouse Design for easy multi-pin snake connection
- Heavy-duty construction with EVA foam interior padding
- Commercial Grade Plated Hardware
- (4) Heavy-duty Casters (2) locking

Doghouse Design for  
Multi-Pin Snake  
Connection Allowing  
Use While in the Case



**A HA60 PA System**  
 620807 MSRP \$299.99 **\$199<sup>99</sup>**  
**HAT120 Portable PA System**  
 423427 MSRP \$449.99 **\$299<sup>99</sup>**

**A. HA60 PA SYSTEM**

**Ideal for parties or presentations.** The Harbinger HA-Series portable PA systems are among the most value-oriented products in their category. Both include a powered mixer and a pair of speakers, the HA60 featuring 60 watts and 10" woofers, and the HA120 featuring 120 watts and 12" woofers. Both include a two-band EQ per channel, effects and a pair of 20' speaker cables. Ideal for parties, presentations, DJs, and more.



**B XP150 Portable PA System**  
 H82016 MSRP \$419.99 **\$329<sup>99</sup>**

**B. XP150 PORTABLE PA SYSTEM**

**A PA that goes wherever you do.** The Expedition XP150 by Samson is a portable PA system that combines powerful stereo sound with portability and simplicity. The XP150 packs up into a single unit that weighs only 24 pounds. It is perfect for schools, conferences and presentations, as well as musicians and singer-songwriters. Lightweight, durable, and professionally presentable, the Samson XP150 is a perfect sound reinforcement solution for many situations.



**C Audio Performer Pack Portable PA**  
 631378 MSRP \$549.99 **\$439<sup>99</sup>**

**D Messenger Portable Sound System**  
 601060 MSRP \$499.99 **\$499<sup>99</sup>**

**C. AUDIO PERFORMER PACK PORTABLE PA**

**Complete, portable PA system includes every link in the audio chain.** Includes the 4-channel (10-input), 100W PVi 4B powered mixer with reverb control on each channel; record out for taping; and RF interference protection on all inputs. 2 PVi 10 premium loudspeaker enclosures, 2 PVi 100 dynamic mics with on/off switch, a pair of adjustable speaker stands and cables for the mics and speakers, a carrying pouch and mic clip complete the package.

**D. MESSENGER PORTABLE SOUND SYSTEM**

**A briefcase-sized, complete sound system.** Only 27" wide when packed away, it takes just seconds to set up, making it the ultimate travel multimedia PA. The Messenger Portable Sound System has a 5-channel mixer, 100W output, 2 speakers (each with a 4" woofer and 1" tweeter), storage space, and a 5-band EQ with FLS feedback control. It comes with a mic, mic cable, and speaker cables. The lid functions as a lectern. 29lb.



**E Passport 300 Pro**  
 300W, 8" woofer, 6-channel mixer.  
 423205 MSRP \$999.99 **\$699<sup>99</sup>**  
**Passport 500 Pro**  
 500W, 10" woofer, 8-channel mixer, record to USB flash.  
 423206 MSRP \$1499.99 **\$999<sup>99</sup>**

**Passport 150 Pro**  
 150W, 5.25" woofer, 4-channel mixer.  
 423204 MSRP \$599.99 **\$399<sup>99</sup>**  
**Passport P-10**  
 27W, 5" full-range speaker, includes mic.  
 480661 MSRP \$279.99 **\$199<sup>99</sup>**  
**Passport Executive**  
 100W, 12"x9" flat-panel speaker  
 485709 MSRP \$799.99 **\$599<sup>99</sup>**

**E. PASSPORT PA SYSTEMS**

**Lightweight gear with a heavyweight performance.** Passport PA Systems make it easy to sound good wherever you are. One of the best things about the Passport PA system's powerful clear sound is that you can carry it with one hand, in one trip. Passport systems are ideal for whatever your application may be - education, sporting and worship events; meetings, seminars and presentations; gigs at parties, small clubs and coffee houses.



**NEW LOWER PRICE**



**EON SERIES**

The EON Series from JBL represent a line of portable loudspeakers with an incredible range, enhanced sonic performance, and an extremely functional design. These self-powered, lightweight speakers offer wide and even sound coverage, and come in a variety of sizes and price points that will fit any budget. Check online at [musiciansfriend.com](http://musiciansfriend.com) for more details.

**EON 510 Powered PA Speaker**

10" two-way, bass-reflex design.  
501163 MSRP \$779.00 ~~\$629.99~~ **\$399<sup>99</sup>**

**EON 315 Powered PA Speaker**

15" two way, bass-reflex design, 280W.  
501164 MSRP \$679.00 ~~\$549.99~~ **\$399<sup>99</sup>**

**EON 515XT Powered PA Speaker**

15" two-way, bass-reflex design, 625W.  
H70074 MSRP \$899.00 ~~\$699.99~~ **\$499<sup>99</sup>**

**EON 518S Powered Subwoofer**

18" bass-reflex design, 500W.  
500919 MSRP \$1,129.00 ~~\$899.99~~ **\$699<sup>99</sup>**



600430

**UP TO \$100 INSTANT REBATES**

**JRX112M 12" Stage Monitor**

60Hz-16kHz, 250W/1000W power rating.

600432 MSRP \$409.00  
**\$289<sup>00</sup> Before Rebate \$214<sup>00</sup> After Rebate**

**JRX125 Dual 15" Loudspeaker**

36Hz-16kHz, 500W/2000W power rating.

600431Ø MSRP \$609.00  
**\$449<sup>00</sup> Before Rebate \$349<sup>00</sup> After Rebate**

**JRX115 15" Loudspeaker**

38Hz-16kHz, 250W/1000W power rating.

600430‡ MSRP \$419.00  
**\$299<sup>00</sup> Before Rebate \$224<sup>00</sup> After Rebate**

**JRX118S Subwoofer**

18" woofer with cast-aluminum frame.

600433 MSRP \$699.00  
**\$499<sup>00</sup> Before Rebate \$399<sup>00</sup> After Rebate**

**JRX SERIES**

Big JBL sound, at an affordable price. JRX by JBL is a reasonably priced, professional quality speaker system available in a variety of configurations. They are 2-way systems with a woofer and a compression driver with 1" exit, and a Progressive Transition Waveguide horn. The JRX series also feature a dual-socket polemount system and rugged construction.



**PRX SERIES**

The PRX Series represents a line of passive and powered loudspeakers with the sensitivity, frequency response and the power handling needed to address a wide range of demanding environments. Ideal for musicians, DJs, public address and more, the PRX Series deliver a high-performance sound in a portable PA system.

**PRX612M**

12" 2-Way self-powered stage monitor.  
H05528 MSRP \$1,299.00 **\$699<sup>00</sup> ea**

**PRX615M**

15" 2-Way, self-powered stage monitor.  
H05530 MSRP \$1,449.00 **\$799<sup>00</sup> ea**

**PRX635**

15" 3-Way self-powered loudspeaker.  
H05527Ø MSRP \$1,599.00  
**\$999<sup>00</sup> ea**

**PRX618S-XLF**

18" Self-powered subwoofer system.  
H05529Ø MSRP \$1,849.00  
**\$1149<sup>00</sup> ea**



180248



**DriveRack PX**

With 2 XLR inputs and 2 XLR outputs.  
180248 MSRP \$599.95 **\$399<sup>95</sup>**

**DriveRack PA+**

With 2 XLR inputs, 6 XLR outputs, and additional settings.  
620494 MSRP \$749.95 **\$499<sup>95</sup>**

**XTi 4002 Power Amplifier**

Power and sophistication in a single package. Crown's XTi 2 Series simultaneously embodies brute strength and contemporary innovation. From a 650W per side stereo operation at 8 ohms to a 3200W bridge-mono operation at 4 ohms, this amp has more muscle than you might expect.

H72038 MSRP \$1,999.00 **\$999<sup>00</sup>**

**XTi 2002 Power Amplifier**

H72041 MSRP \$1,399.00 **\$699<sup>00</sup>**



H72038



**CROWN**  
by HARMAN

**XLS1500 DriveCore Series Power Amp**

Drive your PA with maximum power. The XLS Series Power Amps may be lightweight, but produce up to 2,400W over the 4 models. They employ DSP control for mode and crossover functions and Peak Limiters allow maximum output while protecting your speakers.



485460

485460 MSRP \$699.00 **\$399<sup>00</sup>**

**XLS2500 Power Amp**

485462 MSRP \$1,099.00 **\$599<sup>00</sup>**



630487



630490

**Powerpod 620 Plus/S712 PA Package**

**A feature-rich PA at an affordable price.** It includes the Phonic 620 powered mixer and 2 Phonic S712 12" 2-way speakers with piezo tweeters. The mixer has 6 mic/line input channels each with 2-band EQ, 32/40-bit digital effects with 100 footswitchable programs, monitor and main effects sends, phantom power, 6 mic inputs, 8 line inputs, 2 super Hi-Z inputs for instruments, and a 7-band graphic equalizer. A 200W (100W + 100W) gives it plenty of volume. Includes two 20' speaker cables and dynamic mic with cable.

630487Ø MSRP \$739.97 **\$349<sup>99</sup>**

**Powerpod 740 Plus/S712 PA System**

Same as 630487 with Phonic 740 7-channel mixer.

630488Ø MSRP \$819.97 **\$379<sup>99</sup>**

**Powerpod 780 Plus/S715 PA Package**

**A perfect setup for bands with a big sound.** Includes the Phonic 780 Plus powered mixer and 2 Phonic S715 15" 2-way speakers with piezo tweeters. The mixer has 7 mic/line input channels, each with 3-band channel EQs, rumble filters, 24-bit digital effects with 16 footswitchable programs, monitor and main effects sends, phantom power, 7 mic inputs, 10 line inputs, 2 super Hi-Z inputs for instruments, 2 built-in limiters, and dual 7-band graphic EQs. A 600W (300W + 300W) amp gives it plenty of volume. Includes two 20' speaker cables and dynamic mic with cable.

630490Ø MSRP \$1,139.97 **\$449<sup>99</sup>**



502577



630486



630485

**Powerpod 820/S710 PA Package**

**Small, affordable, and loaded with features.** Includes a Powerpod 820 powered mixer with 200W stereo power, 4 mic/line mono channels, 2 stereo channels, 16 - 32-bit digital effects; and 2 - 10" S710 2-way speakers. Includes dynamic mic and cable, plus speaker cables.

502577 MSRP \$739.97 **\$299<sup>99</sup>**

**Powerpod 820/S712 PA System**

Same as 502577 with two S712 12" 2-way speakers.

502578‡ MSRP \$899.97 **\$349<sup>99</sup>**

**Powerpod 620 Plus/S710 PA System**

**A feature-rich PA at an affordable price.** It includes the Phonic 620 powered mixer, and 2 Phonic S710 10" 2-way speakers with piezo tweeters. The mixer has 6 mic/line inputs (each with 2-band EQ), 32/40-bit digital effects with 100 footswitchable programs, monitor and main effects sends, phantom power, 6 mic inputs, 8 line inputs, 2 super Hi-Z inputs for instruments, and a 7-band graphic EQ. 200W stereo power give it plenty of volume for smaller venues. Includes two 20' speaker cables and dynamic mic with cable.

630486‡ MSRP \$579.97 **\$299<sup>99</sup>**

**Powerpod 410/S710 PA Package**

**A small system that has surprising output.** Includes a Phonic 410 powered mixer and 2 Phonic S710 10" 2-way speakers with piezo tweeters. The mixer has 4 mic/line input channels (each with 2-band EQ), built-in digital effects, and a 7-band graphic equalizer. A 100W amplifier gives it plenty of volume. Includes two 20' speaker cables and dynamic mic with cable.

630485‡ MSRP \$489.97 **\$199<sup>99</sup>**



### DXS SERIES



### DXR SERIES

Yamaha has applied all its experience in sound system design and engineering to create an outstanding new breed of powered PA cabinets. Combining efficiency with 1100W power and lightweight with ultra-precise 48-bit DSP sound, the DXR series are designed for maximum clarity and punch at maximum SPL.

- DXR8 2-Way Active DSP-Controlled Loudspeaker**  
H80008 MSRP \$829.00 **\$549<sup>99</sup>**
- DXR10 10" 2-Way Active DSP-Controlled Loudspeaker**  
H80007 MSRP \$899.00 **\$599<sup>99</sup>**
- DXR12 2-Way Active Loudspeaker**  
H80010 MSRP \$1,049.00 **\$699<sup>99</sup>**
- DXR15 2-Way Active DSP-Controlled Loudspeaker**  
H80011 MSRP \$1,199.00 **\$799<sup>99</sup>**

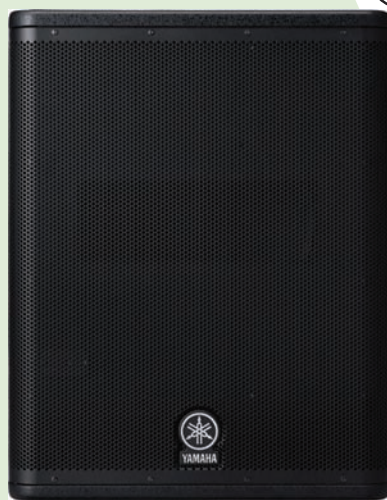

**DXS15 Active Subwoofer**  
Time to deliver some serious low end. The DXS15 subwoofer delivers powerful, focused low end reaching as low as 42Hz. The DXS's fully optimized band-pass design combines with its powerful Class-D amplifier, long travel 15" woofer, and formidable DSP to deliver a tight, impressive bass with outstanding depth and high power output.  
H80012 MSRP \$1199.00 **\$799<sup>99</sup>**

**DXS12 Active DSP Controlled Subwoofer**  
H80009 MSRP \$1049.00 **\$699<sup>99</sup>**

### MG SERIES

The Yamaha MG Series mixers are compact, lightweight and affordable. They feature everything critical to effective mixing along with some very nice extras. Among the "must-haves" are a wide variety of inputs and outputs (XLR/TRS/RCA), auxiliary loops, EQ and built-in effects. There is also convenient adjustable compression on select channels in each of the MG models. The larger versions of the series feature faders, channel mutes, submixing, and a sweepable midrange in the EQ.



**MG102C**  
10-Input stereo mixer  
630138 MSRP \$129.00 **\$99<sup>99</sup>**

**MG82CX**  
8-Input stereo mixer w/effects  
630139 MSRP \$209.00 **\$159<sup>99</sup>**

**MG124CX**  
12-Input mixing console  
630142 MSRP \$369.00 **\$289<sup>99</sup>**

**MG166CX**  
16-Input mixing console  
630257 MSRP \$549.00 **\$429<sup>99</sup>**

### STAGEPAS SERIES



**STAGEPAS 400i**  
Two 400W 8" speakers, with 8-channel mixer  
H92143 MSRP \$949.00 **\$699<sup>99</sup>**

**STAGEPAS 600i**  
Two 680W 10" speakers with 10-channel mixer  
H92144 MSRP \$1,249.00 **\$899<sup>99</sup>**

The STAGEPAS series from Yamaha are an all-in-one PA system that you can take anywhere you wish. Both the 400i and the 600i feature two sleek, lightweight speakers and a detachable powered mixer, along with one pair of speaker cables and a power cord, giving you a complete, extremely portable sound solution. Each of these models are also now equipped with a subwoofer output that automatically assigns a HP filter for extended low end.

### MGP SERIES



Rugged and durable from the outside in and sonically sweet from the inside out, the Yamaha MGP Series Mixers are the perfect solution for bands and venues that need a great sounding console. The series comes in 12-channel and 16-channels, with studio-grade preamps, X-pressive EQ, and digital effects.

**MGP12X**  
H80827 MSRP \$829.00 **\$649<sup>99</sup>**

**MGP16X**  
H80828 MSRP \$999.00 **\$799<sup>99</sup>**



# BOSE

**10% OFF**  
valid until 6/30/13

**L1 SERIES**

H79831



H87408



H85941



H79835

BOSE L1 portable line array systems combine PA and monitors into one single, extremely portable unit. By positioning the L1 speakers behind you, or off to the side while performing, you'll be able to hear what the audience is hearing. Choose from 6-, 12-, and 24-speaker combinations, with or without a bass module, or add on a T1 ToneMatch audio engine for advanced tone control. So many configuration possibilities, find the one that works best for you.

**L1 Compact System**

6 small speakers in line array.

H85941 ~~\$999<sup>99</sup> Before Rebate~~ **\$899<sup>99</sup> After Rebate**

**L1 Model II System with B2 Bass**

24 small speakers in line array.

H903570 ~~\$2699<sup>00</sup> Before Rebate~~ **\$2429<sup>00</sup> After Rebate**

**L1 Model II System with B1 Bass and ToneMatch**

H798310 ~~\$2998<sup>00</sup> Before Rebate~~ **\$2698<sup>00</sup> After Rebate**

**L1 Model II Double B1 Bass with ToneMatch**

H798380 ~~\$3297<sup>00</sup> Before Rebate~~ **\$2967<sup>00</sup> After Rebate**

**B2 Bass Module**

H87408 ~~\$499<sup>00</sup> Before Rebate~~ **\$449<sup>00</sup> After Rebate**



**\$50 INSTANT REBATE**

**HA300 Compact Portable PA System**

Portable sound system with subwoofer. The Harbinger HA300 delivers big sound in a small priced package. It is a full-range system that features a subwoofer, a vertical array of 4" speakers and a piezo tweeter, with power to run them all and a capable built-in mixer.

H81162 MSRP \$599.99 ~~\$399<sup>99</sup> Before Rebate~~ **\$349<sup>99</sup> After Rebate**



iPhone not included

**Digital Mixer X32**

Make an easy transition from analog to digital. 32-channel total recall digital mixer with fully programmable mic preamps, 16 mix buses, 6-band parametric EQs and dynamics processing, Virtual FX rack featuring 8 true-stereo FX, and high-resolution 7" color TFT with associated controls.

H83114 MSRP \$5,999.99 ~~\$2999<sup>99</sup>~~

**ALTO**  
**ZEPHYR SERIES**

The ZEPHYR Series of mixers have the flexibility of multi-bus routing, giving you greater control over your mix. You can create individual monitor mixes to send back to the band, or submixes of vocals, drums, and more. Some models come loaded with advanced onboard Alesis DSP giving you access to studio-quality digital effects, and a built-in USB audio interface making it easy to record the night's set.



H80849

**ZMX52**  
5-Channel mixer with essential I/O.  
H80849 MSRP \$89.00 **\$49<sup>00</sup>**

**ZMX862**  
6-Channel, 2-bus compact mixer.  
H80274 MSRP \$99.00 **\$69<sup>00</sup>**

**ZMX862**  
8-Channel, 2-bus mixer with FX.  
H80273 MSRP \$219.00 **\$119<sup>00</sup>**

**MACKIE**



iPad not included

**DL1608 iPad Mixer**

Mix from anywhere in the venue. The DL1608 redefines mixing by combining a digital mixer with the mobility of the iPad. 16 Onyx mic pres and 24-bit Cirrus Logic converters guarantee pro quality. iPad control means you can mix from anywhere in the room. Support for up to 10 iPads.

H80461 MSRP \$1,249.99 **\$999<sup>99</sup>**

# MACKIE®

## HANDS-ON-REVIEW

### DLM Series Powered Speakers

Loud meets compact meets cost-effective

By Craig Anderton, Editor Emeritus, Harmony Central

As small- and mid-size venues become increasingly commonplace, the huge PA paradigm is overkill—not just because you don't need that much power, but you also don't want to take up that much space. Mackie's extremely compact DLM series beefs up the "personal PA" concept in multiple ways, making the series scalable from small venues, to monitor systems, all the way up to mid-size venues—and can even offer enough oomph for serious DJ applications.

#### Meet the Family

The line consists of the DLM8 (22lb.) and DLM12 (31lb.) full-range powered speakers, with 8" and 12" speakers respectively and 1.75" compression driver. The DLM12S subwoofer (48lb.) offers a 12" speaker. Each has a total of 2000W peak (1000W RMS) of class D power amplification, and the DLM8 and DLM12 both feature coaxial, vertically-aligned speakers (what Mackie calls "TruSource") so that the sound from the tweeter and woofer emanate from the same point. This provides a more coherent sound and minimizes interference between the two drivers. They also share a common magnet, which simplifies the design and helps reduce weight.

The high power means the amps can handle just about any transient you can throw at them without clipping (protection circuits are there if levels get out of hand), and the quiet onboard "smart" fan rarely needs to kick in. The speaker enclosures use high-impact polycarbonate ABS plastic; the sub opts for wood. 20 gauge speaker grilles provide protection, while the DLM8 and DLM12 have "kickstands" that angle the units at 50 degrees for monitoring applications. Mackie recommends the DL1608 or DL806 digital live sound mixer is a r complement to the DLM system. For more information, see [musiciansfriend.com/mackie](http://musiciansfriend.com/mackie).

#### Size Matters

It's amazing how much level you can get out of a box even as small as the DLM8, which is about the theoretically smallest box that can still hold an 8" speaker. It's super-portable, and you can put it just about anywhere—next time you have to set up in a corner of the bar, you can say "okay" instead of "no way." Load in and out is painless, and the DLM12 isn't much more difficult to lug around. The sub takes more effort to carry but even then, something that can blast the bass at under 50lb. is still pretty impressive.

#### Electronics

The powered speakers include the DL2 onboard digital mixer with two inputs. One has a combo jack and mic/line switch (but no phantom power), while the other input has a combo jack that accommodates instrument or line levels but also includes two RCA phono jacks. A thru jack carries either the signal from input 1, or a mix of the two inputs, which is very helpful for monitor applications. Each input has a level control, 3-band EQ, and send control for one of the 16 onboard effects (various combinations of reverb, chorus, and delay). Globally, there are six EQ-based speaker voicing options, a multi-band feedback reducer, one factory and three user presets, and delay up to 300ms that's separate from the effects for balcony placement and such. All units in the series, including the sub, have bright, readable-in-daylight OLED displays.

#### Sub-Substantial

Mixing and effects aren't relevant for a sub, so it has XLR connections for the two line level ins, two full-range outs for side fills and the like, and two high-pass outs for direct connection to DLM loudspeakers (with presets voiced for DLM and SRM-series full-range speakers). However, the DLM12S is intended for use with other systems too, so the digital crossover controls are exposed. It also folds in speaker protection, three presets, and switchable 300ms delay.

#### Conclusions

The portability, extras, electronics, and cost-effectiveness mean nothing if the sound isn't there—but it sure is. The first word that comes to mind is "clarity," with a clean, smooth sound that never grates and provides a relatively wide sweet spot. Surprisingly, even the DLM8 has sufficient bass that you probably won't need the sub for most applications (an obvious exception is hardcore club music, like techno or dubstep) although of course, if you really want to shake the house then a couple of DLM12 speakers with the sub can handle mid-sized clubs with ease.

The highs are never "screechy," and there's no midrange "boxiness" (you can thank the onboard DSP for that). Compared to some of the "old standby" speakers, the DLM models sound pleasing and even. In short, they achieve that open, "really loud hi-fi system" kind of sound instead of the denser, darker sound sometimes associated with conventional PAs. But one of the most important points

is that all this is achieved in such a portable, compact format. In particular, it's hard to believe the DLM8 can put out so much sound from such a little package. Personal PAs may not be glamorous pieces of gear, but Mackie's manufacturing mojo has resulted in a line that hits a sweet spot of cost-effectiveness, sound quality, scalability, and size.

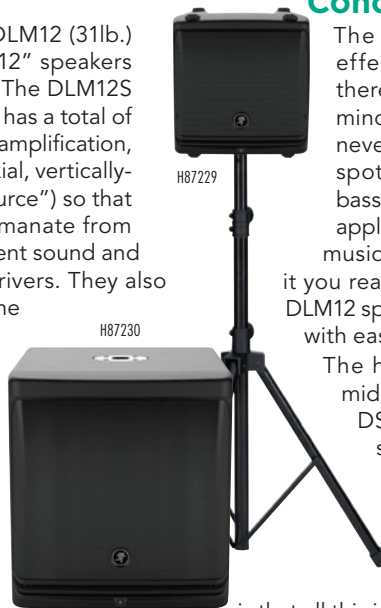

#### Mackie DLM Series powered speaker features:

- Substantial volume from compact enclosures
- Sub complements the line well when you need serious bass punch
- Two-channel mixer with XLR/1/4" combo jack inputs and RCA unbalanced ins
- Free Softube Saturation knob to registered users
- 3-band EQ, fixed delay up to 300ms, 16 effects, and anti-feedback control
- Four presets (one factory, three user)
- Pole-mountable, flyable, or mount on wall
- Multiple forms of speaker protection
- "Kickstand" tilts speakers at 50-degree angle for monitoring applications

Mackie's DLM series is all about maximum levels from the most compact enclosures possible, coupled with sonic clarity and a cost-effective price. Order today with the complete assurance of Musician's Friend's 45-Day Total Satisfaction and Lowest Price Guarantees.

DLM 8  
H87229

\$699<sup>99</sup>

DLM 12  
H87230

\$999<sup>99</sup>

For more Mackie product visit: [musiciansfriend.com/mackie](http://musiciansfriend.com/mackie)



**TRUESONIC SERIES**

**LTO®**

The Truesonic Series was designed to be one of the most transparent loudspeakers available. Through rigorous testing and thousands of listening hours, Alto makes sure that what you put in is what you get out. Each 2-way speaker and sub benefit from the use of Class D amps, and a rugged build design.

<p><b>TS112W with Wireless Connectivity</b> H86605 MSRP \$499.00 <b>\$399<sup>00</sup></b></p> <p><b>TS115A 15" Active Speaker</b> H80848 MSRP \$449.00 <b>\$349<sup>00</sup></b></p>	<p><b>TS115W with Wireless Connectivity</b> H86604 MSRP \$549.00 <b>\$449<sup>00</sup></b></p> <p><b>TSSUB15 15" 1200W Peak Active Sub</b> H80277‡ MSRP \$699.00 <b>\$599<sup>99</sup></b></p>	<p><b>TS110A 630W 10" 2-Way Active</b> H80276 MSRP \$349.00 <b>\$249<sup>00</sup></b></p> <p><b>TS112A 12" Active Speaker</b> H80275 MSRP \$399.00 <b>\$299<sup>00</sup></b></p>
---	--	--

**YAMAHA**



**DSR SERIES**

Yamaha DSR-Series takes portable active loudspeakers to the extreme limits of their potential. Designed through the application of advanced Yamaha digital and acoustic technologies perfected over several decades, DSR provides a listening experience that redefines high-definition sound reinforcement.

**DSR112 Powered PA Speaker**  
12", 2-way active loudspeaker, 1,300W (850W LF/450W HF).  
H02701 MSRP \$1,349.00 **\$899<sup>99</sup>**

**DSR115 Powered PA Speaker**  
15", 2-way active loudspeaker, 1,300W (850W LF/450W HF).  
H02703Ⓞ MSRP \$1,499.00 **\$999<sup>99</sup>**

**STAGESOURCE SERIES**



Using six powerful DSP-based Smart Speaker modes, the StageSource speaker's output is optimized for a variety of performance scenarios including front-of-house PA, floor monitor, personal PA, keyboard backline, acoustic guitar backline, or with a multi-effects guitar processor as a high-performance electric guitar speaker system.

**L3t Powered Speaker**  
1,400W 3-way powered loudspeaker with built-in mixer.  
H81164 MSRP \$1,679.99 **\$999<sup>99</sup>**

**L3s Powered Subwoofer**  
1,200W bi-amped, bass-reflex subwoofer system.  
H81168 MSRP \$1,679.99 **\$1,199<sup>99</sup>**

**MACKIE®**



**Thump TH-12A Powered Loudspeaker**  
High-performance audio without the high price tag. Delivering deep low-end and real power in a light-weight, portable design, it pushes 100W to the HF driver and a bass-pounding 300W to its high-output woofer. Precision crossover and driver time-alignment provide maximum system efficiency. It also features a 3-band EQ for tone control, and can be pole-mounted or used as a floor wedge.  
H71339 MSRP \$389.99 **\$299<sup>99</sup>**

**Thump TH-15A Active Speaker**  
Same as H71339 with 15" woofer.  
485392 MSRP \$469.99 **\$349<sup>99</sup>**



# TAKE CONTROL. ZLX



## VISUAL CONTROL & MONITORING

©2013 Bosch Security Systems, Inc.

ZLX is available in 12" and 15" versions.  
Passive models also available.

New ZLX portable powered loudspeakers stand apart with the most complete, innovative, and user-friendly package of features in their class, giving you more control over your sound to ensure your audience connects with your creative moment, whatever your gig.  
[www.electrovoice.com/zlx](http://www.electrovoice.com/zlx)

- **PRECISION** - DSP with LCD and application/location presets
- **POWER** - Custom-built 1000 W Class-D amplifier
- **PERFORMANCE** - EV-engineered components for superior sound
- **PORTABILITY** - Unique hi/lo grip handles and lightweight construction
- **PRESENCE** - Stunning enclosure design

ZLX-12 12" 2-Way Passive Loudspeaker	H92555	<del>\$299</del> <sup>99</sup>
ZLX-12P 12" 2-Way Powered Loudspeaker	H92553	<del>\$399</del> <sup>99</sup>
ZLX-15 15" 2-Way Passive Loudspeaker	H92554	<del>\$399</del> <sup>99</sup>
ZLX-15P 15" 2-Way Powered Loudspeaker	H92552	<del>\$499</del> <sup>99</sup>

2 ways to shop | [musiciansfriend.com/electro-voice](http://musiciansfriend.com/electro-voice) | 800.217.5207

# QSC™

## K SERIES



All K Series 2-way speakers have a molded ABS cab; 1,000W Class D power amp; 8", 10", or 12" woofer; 1-3/4" compression HF driver; control and time-alignment DSP; a 2-channel mic/line mixer section; EQ presets for normal or enhanced vocals; a DEEP mode for LF extension without a subwoofer; and an HP filter for use with a subwoofer.

**K8 8" Powered PA Speaker**  
581516 MSRP \$759.00 **\$699<sup>99</sup>ea**

**K10 10" Powered PA Speaker**  
581517 MSRP \$899.00 **\$749<sup>99</sup>ea**

**K12 12" Powered PA Speaker**  
581518 MSRP \$999.00 **\$849<sup>99</sup>ea**

**KSub Powered Subwoofer**  
581519Ø MSRP \$1,199.00 **\$1129<sup>99</sup>ea**



H70839

H70837‡

## LIVE X SERIES

For decades, Electro-Voice PA speakers have dominated the stage at high-profile venues and major events worldwide. Bearing that legacy, the Live X Series of powered and passive loudspeakers sets new standards for portable sound, with the latest Electro-Voice-engineered components; lightweight, durable plywood cabinets; best-in-class SPL output, power-handling, and frequency response; and clean, stackable designs – all at a price point previously unheard-of for loudspeakers of a similar pedigree.



**ELX112 Passive 12" Loudspeaker**  
H70840 MSRP \$494.00 **\$299<sup>99</sup>ea**

**ELX118 Passive 18" Subwoofer**  
H70837‡ MSRP \$827.00 **\$499<sup>00</sup>ea**

**ELX115 Passive 15" Loudspeaker**  
H70843 MSRP \$655.50 **\$399<sup>00</sup>ea**

**ELX112P Powered 12" Loudspeaker**  
H70839 MSRP \$989.00 **\$599<sup>00</sup>ea**

# MACKIE®

## DLM SERIES

The DLM Series is comprised of two full-range loudspeakers, plus a powerful subwoofer. This innovative series packs in amazing true-source fidelity, an intuitive built-in digital mixer, and 2000W of class-leading chest-pounding power, all housed in an ultra-compact housing that takes up limited space. This series is perfect for just about any application from DJs to coffee house musicians and everything in-between.



**DLM8**  
8" Full-range powered loudspeaker.  
H87229 MSRP \$899.99 **\$699<sup>99</sup>**

**DLM12S**  
12" powered subwoofer.  
H87230 MSRP \$1,199.99 **\$999<sup>99</sup>**

**DLM12**  
12" Full-range powered loudspeaker.  
H87228 MSRP \$999.99 **\$849<sup>99</sup>**

# K *for* MUSICIANS



Omar **Hakim**

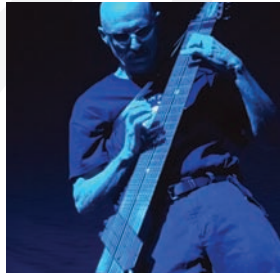

Tony **Levin**



Dave **Mathews**



Dweezil **Zappa**



Dave **Weckl**



Darryl **Jones**



Jonathan **Cain**



Richard **Fortus**

What do these legendary musicians have in common?  
They all play using **QSC K Family Products**.

Think the K Family of loudspeakers is just for PA? Think again. Musicians everywhere are choosing K as their next musical instrument amplifier – and with good reason.

## QSC™

KforMusicians.com

© 2013 QSC Audio Products, LLC. All rights reserved. QSC and the QSC logo are registered trademarks of QSC Audio Products, LLC in the U.S. Patent and Trademark Office and other countries. K for Musicians is a trademark of QSC.

K8 8" Powered PA Speaker	581516	<del>\$699</del> <sup>99</sup>	KW122 Powered Speaker	485942	<del>\$1099</del> <sup>99</sup>
K10 10" Powered PA Speaker	581517	<del>\$749</del> <sup>99</sup>	KW152 Powered Speaker	485943	<del>\$1199</del> <sup>00</sup>
K12 12" Powered PA Speaker	581518	<del>\$849</del> <sup>99</sup>	KW153 Powered Speaker	485944	<del>\$1439</del> <sup>29</sup>
KSub Powered Subwoofer	581519	<del>\$1129</del> <sup>99</sup>	KW181 Powered Subwoofer	485945	<del>\$1499</del> <sup>99</sup>

2 ways to shop | [musiciansfriend.com/qsc](http://musiciansfriend.com/qsc) | 800.217.5207

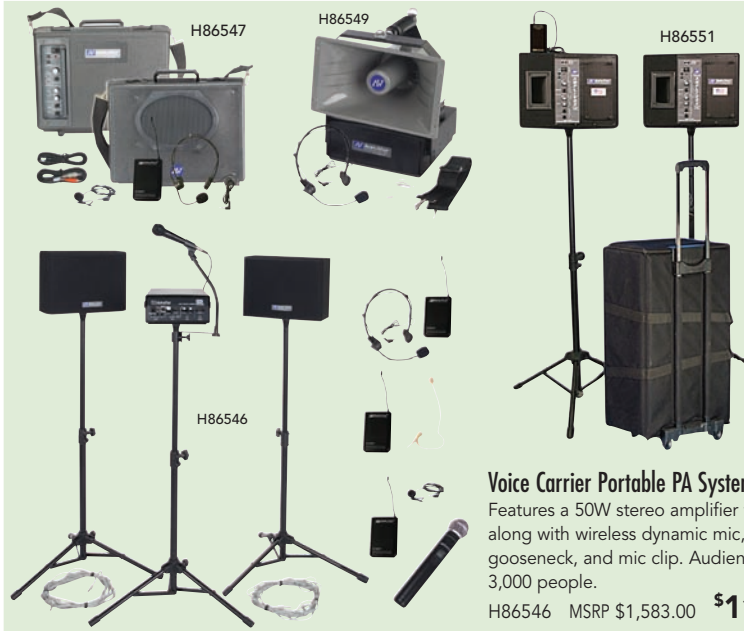

AmpliVox public address systems are designed to be powerful and meet your needs on the go. Simple to use and easy to operate, these PA Systems make setting up a snap indoors or outdoors. Give your next presentation or public address with confidence, knowing you'll be heard loud and clear.

**Portable Buddy PA System**

Features a 50W stereo amplifier with built-in receiver, and wireless lapel and headset mic. Audience sizes up to 1,000 people.

H86547 MSRP \$760.00 **\$532<sup>00</sup>**

**Half-Mile Hailer PA System**

Features a 50W stereo amplifier with 3 inputs, along with wireless headset & lapel mic with transmitter. Audience sizes up to 5,000 people.

H86549 MSRP \$799.00 **\$559<sup>30</sup>**

**Voice Projector Portable PA System**

Features a 50W stereo amplifier, 2 wireless speakers, wireless lapel & headset mic with transmitter, and 2 tripods. Audience sizes up to 3,000 people.

H86551 MSRP \$1,496.00 **\$1047<sup>20</sup>**

**Voice Carrier Portable PA System**

Features a 50W stereo amplifier with 3 inputs, along with wireless dynamic mic, flexible gooseneck, and mic clip. Audience sizes up to 3,000 people.

H86546 MSRP \$1,583.00 **\$1108<sup>10</sup>**



H90452

H90450



**GENERATOR SERIES**

The team at Champion Power Equipment is your source for power that can go anywhere and be ready at anytime. They're dependable, durable, and affordable line of generators range in sizes, but share a common goal. They're ideal for outdoor events, or emergency situations.

**3500 Watt Generator**

3500W running power (400W peak), up to 12 hours of run time.

H90452 **\$425<sup>00</sup>**

**2000 Watt Inverter Generator**

2000W max power, up to 9.5 hours of run time.

H90450 **\$799<sup>00</sup>**

**7500 Watt Electric Start Generator**

7500W running power (9375W peak), 25ft. cable, up to 8 hours of run time.

H90455 **\$899<sup>00</sup>**



H90455



**Mighty-Meg 25-Watt Dynamic Megaphone**

Let your voice be heard, up to a mile away. Far more lightweight than traditional megaphones, the Mighty-Meg 25 uses Piezo technology to achieve a loud and clear projection of your voice. It features a comfortable grip, with three modes of operation. Practical range of up to 1 mile, will ensure you'll be heard.

H86552 MSRP \$180.00 **\$126<sup>00</sup>**



**PHONIC**

**5710 10" 2-Way PA Speaker**

Tough, portable, and very affordable. The 5710 speaker is a starter unit that features a 10" heavy-duty woofer combined for power handling of 80W program/160W peak power handling. You can use the Phonic 5710 both as a floor monitor or mounted as a raised sound reinforcement speaker.

600727 MSRP \$119.99 **\$69<sup>99</sup>**

# On-Stage Stands®



LS7720BLT Lighting  
Stand with Side Bars  
450414  
MSRP \$163.99  
**\$99<sup>95</sup>**

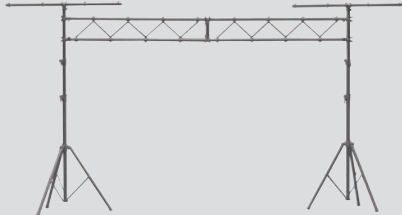

LS7730 Lighting  
Stand with Truss  
450405  
MSRP \$367.99  
**\$199<sup>95</sup>**



SSP7855 Professional  
Speaker Stand Pak  
450458 MSRP \$114.00 **\$89<sup>95</sup>**

# ULTIMATE SUPPORT™



TS-90B Telelock  
Tripod Speaker Stand  
450569 MSRP \$149.99 **\$99<sup>99</sup>**

## MUSICIAN'S GEAR



Standard Speaker Stand Ebony  
451036 MSRP \$99.99 **\$39<sup>99</sup>**



MG280 PA Sound System Stand Kit  
712604 MSRP \$364.95 **\$99<sup>99</sup>**



Speaker Stand Kit  
459556 MSRP \$204.95 **\$99<sup>99</sup>**



Speaker Stand Pair  
360873 MSRP \$199.98 **\$59<sup>95</sup>**

## GEAR ONE™



Garage Band  
Recording Accessories Pack  
583612 MSRP \$254.89 **\$39<sup>99</sup>**



Garage Band  
Live Sound Accessories Pack  
583609 MSRP \$364.87 **\$79<sup>99</sup>**



My First Recording  
Accessories Pack  
583611 MSRP \$219.94 **\$29<sup>99</sup>**



Gigging Pro  
Live Sound Accessories Pack  
583610 MSRP \$504.86 **\$149<sup>99</sup>**

## ODYSSEY®



LT-P2 Tripod Lighting Stand Pair  
801742 MSRP \$155.98 **\$109<sup>98</sup>**



Lighting Tripod and Truss Package  
801743 MSRP \$459.97 **\$219<sup>97</sup>**

## PROLINE®



LST2BK Speaker Stand  
454311 MSRP \$103.99 **\$39<sup>99</sup>**



PLSP1 Speaker Stand  
Set with Bag Black  
581901 MSRP \$180.00 **\$79<sup>99</sup>**



TRS - TRS Balanced Patch Cable  
330496 from \$11<sup>99</sup>



1/4" - RCA Dual Patch Cable  
330490 from \$9<sup>99</sup>

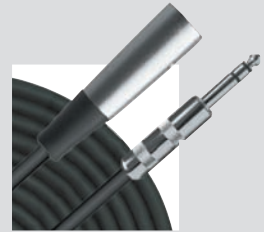

TRS - XLR Male Patch Cable  
331065 from \$11<sup>99</sup>



DMX Cable  
331091 from \$16<sup>99</sup>



12-Gauge Speakon Speaker Cable  
331133 from \$34<sup>99</sup>



16-Gauge 1/4" -  
1/4" Speaker Cable  
331143 from \$9<sup>99</sup>



Headphone Extension Cable - 25 Foot  
330887 MSRP \$16.99 \$13<sup>99</sup>



8-Channel Stage Snake  
339003 from \$109<sup>99</sup>



16-Channel/4-Return Stage Snake  
330474 MSRP \$659.99  
\$299<sup>99</sup>



16x4 Combo  
Input with TRS  
Return Snake  
331090 MSRP \$499.99 \$249<sup>99</sup>



24-Channel/4-Return Stage Snake  
330475 MSRP \$919.99 \$499<sup>99</sup>

MUSICIAN'S GEAR



Musicians Gear TRS to TRS Patch Cable 8-Pack (17")  
330285 MSRP \$39.99 \$9<sup>99</sup>



Banana-1/4" Speaker Cable 14  
Gauge 10' 2-Pack  
583992 MSRP \$41.98 \$9<sup>98</sup>



Speaker Cable  
336620 from \$9<sup>99</sup>



3-Pin DMX Cable  
331770 from \$8<sup>99</sup>



16-Gauge Speaker Cable Black  
330078 from \$4<sup>99</sup>



16 Gauge Speaker Cable Black - 25  
Feet 2-Pack  
582057 MSRP \$39.98 \$17<sup>98</sup>



Pro Series Snake  
430886 from \$399<sup>99</sup>



Gold Studio 1/4" to XLR Male Cable  
339034 from \$39<sup>95</sup>



16 Gauge Speaker Cable Black - 25  
Feet 4-Pack  
582058 MSRP \$79.96 \$29<sup>96</sup>



Stage Snake  
620862 from \$119<sup>99</sup>



StageMASTER Snake  
H78496 from \$379<sup>99</sup>



# FURMAN



Furman Power Conditioners bring together superior protection and outstanding performance in a sturdy, rugged design. Furman's single-space rackmount conditioners feature 1 outlet on the front and 8 on the rear to supply power for up to 9 pieces of gear. Choose a model with pullout lights in front to keep your rack lit in dark studios or stages.

## SS-6B Surge Block

6-outlet strip, 15-foot cord.  
181297 **\$44<sup>99</sup>**

## M-8X2 Power Conditioner

9 outlets  
712515 MSRP \$80.00 **\$64<sup>99</sup>**

## M-8LX Power Conditioner

With pullout lights  
181046 MSRP \$120.00 **\$99<sup>95</sup>**

## M-8DX Power Conditioner

With pullout lights & voltmeter  
181047 MSRP \$160.00 **\$129<sup>95</sup>**

## PL-8C Power Conditioner

With pullout & diagnostic lights  
500823 MSRP \$230.00 **\$189<sup>95</sup>**

## PL-Plus C Power Conditioner

With pullout lights, diagnostic lights, & voltmeter  
500824 MSRP \$280.00 **\$229<sup>95</sup>**

## PRO POWER SERIES

Monster power conditioners and power strips are designed to offer your gear maximum power with better sound and complete protection against electrical surges and spikes for performing musicians, recording studios, project studios and home theaters. Choose from power strips or rack-mount units to best fit your needs.

**Pro 200 Dual Outlet**  
180018 **\$39<sup>95</sup>**

**Pro 800 High Performance Pro PowerCenter**  
182657 **\$79<sup>95</sup>**

**PRO 900 PowerCenter**  
Monster Clean Power Stage 1 filter.  
180015 **\$99<sup>95</sup>**

**Pro 2000 Floor Standing Power Supply**  
182654 **\$199<sup>95</sup>**



**PRO 2500 Rack PowerCenter**  
Monster Clean Power Stage 2 filter.  
182650 **\$199<sup>95</sup>**

**Pro 1000 with Clean Power Stage 2 Power Outlets**  
182653 **\$149<sup>95</sup>**



H71322



H71324



H71323



## POWER STRIPS & CONDITIONERS

LiveWire has the power you need to make great music, and they're committed to producing the very best in cabling and accessory products for your music/audio applications. Choose from a 6-outlet strip with 10-foot cord, or one of the 11-outlet rack mountable power conditioner and distribution systems.

**Power Conditioner and Distribution System**  
H71323 MSRP \$199.99 **\$99<sup>99</sup>**

**Power Strip with 10-Foot Cord**  
H71322 MSRP \$39.99 **\$19<sup>99</sup>**

**Power Conditioner and Distribution System**  
H71324 MSRP \$99.99 **\$49<sup>99</sup>**



H77699



183225

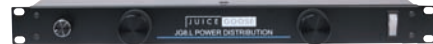

183230

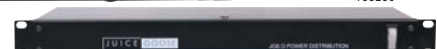

## JG SERIES

The Juice Goose JG family of power and light modules includes six high quality, economical models that are valuable accessories for any rack-mounted system. The switched outlets on the back of each unit provide power while the discreet components inside provide a basic level of protection to help clean up dirty and dangerous AC voltage.

**JG Junior Power Distribution Center**  
183225 MSRP \$66.00 **\$49<sup>99</sup>**

**8.0L Power Distribution Center**  
183230 MSRP \$116.00 **\$116<sup>16</sup>**

**8.0 Power Distribution Center**  
183225 MSRP \$86.00 **\$59<sup>00</sup>**

**JuiceBox**  
H77699 **\$149<sup>00</sup>**



**A VE-5 Vocal Effects Processor**  
H88746 MSRP \$382.50 **\$279<sup>00</sup>**



**C NEO-22**  
H74538 MSRP \$299.00 **\$199<sup>00</sup>**



**E VoiceLive Touch 2**  
H92682 MSRP \$835.00 **\$599<sup>99</sup>**



**B HERO-REC**  
H88764 MSRP \$799.00 **\$599<sup>00</sup>**



**D GIG STAR PRO II**  
481923 MSRP \$719.00 **\$499<sup>00</sup>**



**F JamCube Mini Karaoke System**  
H88704 MSRP \$299.00 **\$249<sup>99</sup>**

**A. VE-5 VOCAL EFFECTS PROCESSOR**

**Easy one-touch vocal effects.** The VE-5 Vocal Performer is a compact and mobile personal effects processor and looper for vocalists. Featuring a simple-to-use tabletop design easily attachable to a mic stand for performing, the VE-5 is perfect for singers, rappers, beatboxers, webcasters, and anyone who wants to have fun with processing vocal sounds.

**B. HERO-REC**

**Portable PA system with digital recorder.** All the power you need to command the attention you deserve. The HERO-REC is a compact and portable 120W 4-speaker stereo system with a 4-channel pro mic/line mixer and multi-format disc player that also supports SD & USB playback. Jam along with backing tracks or band members, and record it with the built-in SD recorder.

**C. NEO-22**

**Multiformat Karaoke player with recording ability.** If you're looking for a karaoke player that can do it all, the Neo-22 is an excellent choice. Due to its multiformat capability and recording function, the Neo-22 is currently one of the most sought after machines. Along with its aesthetically pleasing look and feel, this model makes it easy to operate, record, and rip your music.

**D. GIG STAR PRO II**

**Complete Karaoke package with mic.** This complete Karaoke system has everything you need for some serious fun and entertainment. This package includes the GIG STAR Jam Along system with built-in digital tuner that can handle multiple file formats, and pairs it up with a VHF-3000 dual-channel VHF wireless mic that will have you sounding your very best. Check online for more details.

**E. VOICELIVE TOUCH 2**

**Total voice control with a simple touch.** Touch 2 is the next generation in the TC Helicon compact vocal effects series. Building on the success of the original, this updated version gives singers even more opportunities to hone their instrument and create new sounds with state-of-the-art effects and performance looping, all in a compact and intuitive touch layout.

**F. JAMCUBE MINI KARAOKE SYSTEM**

**Your portable PA on-the-go.** The JamCube is a lightweight, full-featured, mini karaoke PA system, and with its adjustable shoulder strap, super easy to transport. The system is built around a 4-channel mixer that can accommodate both microphones & instruments. Its built-in media player will play just about every kind of disc out there. The onboard USB port and SD card slot can access additional media files.

**G. SONIC MAXIMIZER**

**Maximize and restore audio signal clarity.** The BBE Sonic Maximizer series will restore the brilliance and clarity to an audio signal. Ideal for DJ and PA sound reinforcement, musical instruments, and recording, the BBE Sonic Maximizers are perfectly suited for maintaining accurate signals in both studio and live sound applications.



180913



**G 482i Sonic Maximizer**  
Dual-mono operation with unbalanced I/O  
180913 MSRP \$299.99 **\$179<sup>99</sup>**

H13464



**382i Stereo Sonic Maximizer**

Single-channel operation with unbalanced I/O.  
H13464 MSRP \$142.00 **\$99<sup>99</sup>**

180914



**882i Sonic Maximizer**

Dual-mono operation with balanced I/O.  
180914 MSRP \$499.99 **\$249<sup>99</sup>**



by HARMAN



**A** K267 TIESTO - DJ Reference Over Ear Headphones  
H89673 MSRP \$399.00 **\$349<sup>99</sup>**

**Pioneer**



**B** HDJ-1500-K DJ Headphones  
H80582 MSRP \$209.00 **\$179<sup>00</sup>**

**C** HDJ-500 DJ Headphones  
H70094 MSRP \$125.00 **\$99<sup>99</sup>**

**A. K267 TIESTO HEADPHONES**

Exceptional DJ reference headphones styled by DJ TIESTO. The K267, part of the "AKG by TIESTO" range of headphones, features tuning and styling directed by legendary DJ and producer TIESTO. With its over-ear design, anodized aluminum parts, dual plug-in cable feature, and 3D-Axis folding, the K267's performance raises the bar for the professional DJ.

**B. HDJ-1500-K DJ HEADPHONES**

Professional DJ headphones with full-range sound. These pro-DJ headphones promise to deliver full-range, incredible sound reproduction in a stylish cosmetic design that is perfect for pro DJs. The HDJ-1500 utilizes high-quality components, large drivers, high-quality construction and a new sound isolation technology.

**C. HDJ-500 DJ HEADPHONES**

Professional DJ headphones built to match beats. Urethane ear pads, wrapped in leather, mold around your head and ears for a snug, slip-resistant fit. Crafted with a magnesium alloy for durability, rotating arm structure for maximum monitoring flexibility, and 2 interchangeable cords providing freedom of movement.

**D. RED WAVE DJ MIXING HEADPHONES**

Designed for working DJs with high-isolation earcups and stylish, functional design. RED WAVE headphones were designed with the entire DJ experience in mind. Their superior sound, eye-catching looks, and comfortable design make RED WAVE headphones an ideal choice for professional DJs. Swivel design for monitoring, clean and powerful output, and breathable protein-leather earcups for comfort.

**E. REDPHONE FULL-RANGE DJ STICK HEADPHONE**

Tired of being leashed to your rig with headphones around your neck? REDPHONE is a stick-style monitoring headphone designed to free you up so you can perform at your best. Based upon Numark's acclaimed RED WAVE headphones, REDPHONE channels your mix through a premium-quality 50 mm driver, providing superior monitoring at every gig.

**Numark**



**D** RED WAVE DJ Mixing Headphones  
H71207 MSRP \$199.00 **\$99<sup>95</sup>**



**E** REDPHONE Full-Range DJ Stick Headphone  
H80526 MSRP \$149.00 **\$69<sup>00</sup>**

**SHURE**



**F** SRH750DJ Professional DJ Headphones  
583392 MSRP \$188.00 **\$149<sup>99</sup>**

**F. SRH750DJ PROFESSIONAL DJ HEADPHONES**

Comfortable and durable headphones will keep you in the mix. High impedance and maximized-power handling, make these headphones ideal for use with DJ mixers. The comfort-padded ear cups swivel 90-degrees and allow easy one ear monitoring. Replaceable cable and included set of replacement ear pads ensure a long-lasting lifetime of use.

**SENNHEISER**



**G** HD 25 II Headphones  
241419 **\$249<sup>95</sup>**

**AMERICAN AUDIO**



**H** HP550 Professional Studio Headphones  
485879 MSRP \$69.95 **\$49<sup>99</sup>**

**G. HD 25 II HEADPHONES**

Capable of handling high SPLs in noisy settings. Offers high attenuation of background noise and can handle very high sound pressure levels. They perform exceptionally well in high-noise environments such as sound reinforcement and field recording, as well as studio monitoring. The capsule can be rotated for one-ear listening, making them ideal for DJs.

**H. HP 550 DJ HEADPHONES**

A reliable set of studio headphones for working DJs. The soft-touch comfortable housing, convenient one ear monitoring, and easy folding design make these cans perfect for DJs. The HP 550 are equipped with a pair of 1/4" adapters, each with a locking nut to prevent accidental unplugging during a gig. Includes long cable and storage bag.



# Pioneer

**DDJ-SX DJ Controller**  
**Intuitive, dedicated control built for Serato DJ.** The DDJ-SX is an all-in-one performance controller, with a tactile approach to mixing digital music. This hands-on DJ controller is overflowing with features like CDJ-type jog wheels, 16 touch-responsive pads, and more; all completely mapped for control of the included Serato DJ software.  
 H86622 MSRP \$1199.00 **\$999<sup>00</sup>**



# NI NATIVE INSTRUMENTS

**TRAKTOR KONTROL S4 DJ Controller**  
**Powerful 4-deck control of TRAKTOR PRO 2.** The S4 fuses a premium-quality, 4-channel DJ mixer; 24-bit/96kHz soundcard; an intuitive controller; 2 high-res, touch-sensitive jog wheels; and flagship TRAKTOR PRO 2 software into one fully professional solution. It's a one-stop package for DJs who want pro features, instant usability and easy portability.  
 H65629 MSRP \$999.00 **\$799<sup>99</sup>**

# Numark



**4TRAK 4-Channel Traktor Controller**  
**4-Channel DJ controller mapped for TRAKTOR PRO.** The Numark 4TRAK is an aluminum constructed DJ controller with four-decks of seamless TRAKTOR Pro software control. With its four-channel mixer and 12-knob FX KOMMAND CONSOLE, you will be in complete hands-on control of all TRAKTOR PRO features, filters and effects to enhance any mix.  
 H80557 MSRP \$1499.00 **\$699<sup>99</sup>**

**NS6 Digital DJ Controller**  
**4-channel digital DJ controller with effects.** A true DJ controller, the NS6 gives you tons of versatility and control for professional DJs. NS6's easy-to-use dual-platter system has been designed in collaboration with Serato to deliver powerful breakthrough performance. Includes a copy of Serato ITCH.  
 H71214 MSRP \$1299.00 **\$699<sup>99</sup>**

# Numark

PRE-ORDER TODAY

NEW



**A Orbit**  
H95063  
MSRP \$149.00  
**\$99<sup>95</sup>**

**A. ORBIT**  
Out of this world MIDI control for the DJ. The Numark Orbit packs massive MIDI control into a compact and intuitive design that fits comfortably in your hands. Every inch is tailor-made for live DJ performance and powerful wireless control. Orbit is 100% MIDI-customizable. Wirelessly manipulate effects, launch samples and hot cues, control software, trigger lighting, and more.



NEW

**B Mixtrack Pro II**  
H92762 MSRP \$399.00  
**\$299<sup>95</sup>**

**B. MIXTRACK PRO II**  
New design, enhanced features, same attitude. This next-generation version encompasses all the great and inspiring features from the original, but adds a bit more flavor. Now with 16-backlit drum pads and illuminated touch-activated platters, Mixtrack Pro II is well-suited to play hard.

NEW LOWER PRICE



**C NS7FX**  
485422 MSRP \$1799.00  
**\$999<sup>99</sup>**

**C. NS7FX**  
High-resolution digital control of Serato ITCH. The NS7FX boasts tactile control with dual direct-drive platters, and is loaded with features like a built-in 24-bit interface, Strip Search virtual needle drop, MIDI control, integrated laptop stand, and extensive mix controls.



**D iDJ Pro**  
H80558 MSRP \$699.00  
**\$499<sup>00</sup>**

**D. iDJ PRO**  
Premium DJ controller powered by iPad. Expands your iPad's touch interface, seamlessly integrating with Algoriddim's djay for iPad app to form a completely new DJ experience. Features a sleek, brushed aluminum casing and is equipped with all the professional controls you expect, plus some design features and capabilities that will inspire new surges of creativity.

**E. DN-MC6000**  
Integrated digital mixer and MIDI controller. The DN-MC6000 features intuitive 4-deck software control with visible deck color change, realtime matrix operation, and 2x2 USB audio interface. Its intuitive layout offers MIDI FX controls, dual jog wheels, mixer section, and more.

## DENON

**\$100 MAIL-IN REBATE**



**E DN-MC6000**  
H68105 MSRP \$949.99  
**\$799<sup>99</sup> Before Rebate**

## Vestax



**F VCI-380**  
H83491 MSRP \$1,399.00  
**\$899<sup>99</sup>**

**F. VCI-380**  
The true definition of controllerism. Mix, scratch, cue, effect, sample, trigger, loop and slice tracks with the 2 x 8 banks of FSR trigger pads and classic FX controls, and the built-in 2-channel mixer is more than capable of working on its own to mix-in 2 external devices such as phono or CD sources.

## Pioneer



**G DDJ-WeGO**  
H86857 MSRP \$399.00  
**\$299<sup>00</sup>**



**H DDJ-ERGO**  
H78290 MSRP \$699.00  
**\$499<sup>99</sup>**

**G. DDJ-WeGO**  
Customizable, multi-colored LEDs for visual cues. The DDJ-WeGO is a small-sized, lightweight DJ controller with the looks and style to fit right into any setup. This slimline controller has all the features you need to get your hands on your favorite digital music. Take control of your performance with various effects and get visual mixing cues from the multi-colored LEDs. Includes a copy of Virtual DJ LE.

**H. DDJ-ERGO**  
Versatile, color-illuminated DJ controller. This ultra-compact controller gives any music enthusiast the ability to make his or her own unique music mixes. Bundled with the Virtual DJ Limited Edition software by Atomix Productions, the DDJ-ERGO controller enables you to be creative with your music collection as soon as you take the unit out of the box.

Pioneer



**A RMX-1000 Remix Station**  
H88703 MSRP \$999.00 **\$799<sup>00</sup>**



**D CDJ-2000nexus**  
H86620 MSRP \$2,399.99 **\$1999<sup>99</sup>**



**F DJM-900nexus**  
H72427 MSRP \$2,399.00 **\$1999<sup>99</sup>**



**H DJM-2000 Professional DJ Mixer**  
486076 MSRP \$3,000.00 **\$2499<sup>99</sup>**

stanton



**B T.92 USB Turntable**  
500735 MSRP \$455.00 **\$299<sup>00</sup>**



**C STR8.150 Digital Turntable**  
801078 MSRP \$999.00 **\$599<sup>00</sup>**

Numark



**E TTUSB**  
801258 MSRP \$299.00 **\$99<sup>95</sup>**

RANE



**G SL2 Interface for Serato Scratch**  
H74244 MSRP \$629.00 **\$499<sup>00</sup>**



**I Sixty-Eight DJ Mixer**  
486157 MSRP \$3,299.00 **\$2599<sup>00</sup>**

**A. RMX-1000 REMIX STATION**

**Don't just play it, remix it live.** The RMX-1000 is a powerful, compact and portable remix station that encourages DJs to take their performance to the next level of creativity. Get intuitive control of your music, with built-in effects, build-ups, breakdowns, rhythm and timbre changes, and a touchpad section that lets you add your own parts to the music.

**B. T.92 USB TURNTABLE**

**For DJs and audiophiles who want to digitize their vinyl.** In addition to USB and S/PDIF outputs, the direct-drive T.92 features an S-shaped tone arm for lower distortion and reduced record wear plus built-in DSP with keylock for controlling tempo without affecting pitch. Included PC/Mac software makes conversion a snap.

**C. STR8.150 DIGITAL TURNTABLE**

**Super high-torque DJ turntable.** Stanton went back to basics when creating the STR8-150, a turntable that has everything a DJ needs and nothing they don't. The STR8-150 has a "skip proof" straight tone arm, industry-leading torque motor, and a heavy-duty steel construction that is designed to help minimize feedback.

**D. CDJ-2000NEXUS**

**Pioneer's flagship multi player receives some improvements.** The CDJ-2000nexus, offers exciting enhancements and upgraded technology including Wi-Fi connectivity, compatibility with rekordbox music management software, 6.1" full color LCD display with new GUI, Pro DJ Link ability, added performance functions and more. Check online at our website for more details.

**E. TTUSB**

**Makes it easy to transfer vinyl to MP3.** Transfer your vinyl collection to a computer, then use the included software to remove the clicks, pops, and other noises.

**F. DJM-900NEXUS**

**4-Channel Professional DJ Mixer with effects.** The DJM-900nexus is a high-performance digital mixer designed for today's professional DJs. An ideal combination with Pioneer's latest CDJ line of players, the DJM-900nexus offers a multitude of new features including a variety of onboard effects, increased sound quality, and direct PC or Mac connection.

**G. SL2 INTERFACE FOR SERATO SCRATCH**

**An industry leader in vinyl emulation.** The Rane SL 2 gives you the freedom to take your entire digital music collection on the road with advanced features. This intuitive system replicates the traditional DJing experience for "real feel" usability. Low latency means the response time from touching the decks to hearing an audio signal is extremely fast.

**H. DJM-2000 PROFESSIONAL DJ MIXER**

**Industry-first 5.8" color multi-touch display.** The DJM-2000 is a master control hub that will take your performance to soaring new heights. Featuring major advancements in digital DJ technology the DJM-2000 hosts a 5.8" full color multi-touch display, and a Pro DJ link function that will seamlessly connect up to four CDJ-2000/900 media players.

**I. SIXTY-EIGHT DJ MIXER**

**Support for two computers up to four virtual decks.** Armed with studio-grade phono preamps, dual-USB 2.0 ports and S/PDIF inputs, the Rane Sixty-Eight can allow a blend of analog and digital audio sources like never before. The Sixty-Eight features easy-to-use internal digital effects, and direct control of over 30 Scratch Live library, cue, and loop functions.



For full selection, visit  
[musiciansfriend.com/american-dj](http://musiciansfriend.com/american-dj)



**A JellyDome**  
 H64968 MSRP \$259.95 **\$169<sup>99</sup>**

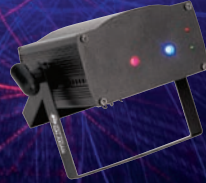

**B Micro Royal Galaxian Laser**  
 H83867 MSRP \$209.95 **\$149<sup>99</sup>**



**C Comscan LED System**  
 485711 MSRP \$699.95 **\$499<sup>99</sup>**



**D Vizi LED Spot**  
 H14036 MSRP \$1,199.95 **\$749<sup>99</sup>**



**E M520L 12" Mirror Ball**  
 803203 MSRP \$124.95 **\$89<sup>99</sup>**



**F Micro Galaxian Laser**  
 H70505 MSRP \$139.95 **\$99<sup>99</sup>**



**G Dyno-Fog II Fog Machine**  
 800573 MSRP \$139.95 **\$99<sup>99</sup>**



**H DUO STATION**  
 H77648 MSRP \$209.95 **\$149<sup>99</sup>**

**A. JELLYDOME**

**Two cool LED effects in 1 small fixture.** The Jellydome is a moonflower dome LED lighting effect with a glowing transparent case that adds to its look. The Jellydome can produce up to seven different colors, at a wide 135-degree beam angle for maximum coverage. Use the color strobe effect and 3 separate operational modes to further enhance its performance.

**B. MICRO ROYAL GALAXIAN LASER**

**Shower the crowd with eye-catching lasers.** The Micro Royal Galaxian is an energizing laser effect capable of producing more than 200 red and blue, high-intensity laser patterns that can be projected on a ceiling, wall or dance floor. Gain control over programs, colors, and black out with the included RF wireless remote or run in Auto mode.

**C. COMSCAN LED SYSTEM**

**A complete LED lighting system with controller.** The Comscan LED system gives you two Comscan LED scanners, one easy-to-use UC3 controller, and one 10' DMX cable. Comscan LED scanners are compact, portable DMX scanners with an advanced, high-performance LED source. Match that with the UC3 controller and you've got a system that puts your show first.

**D. VIZI LED SPOT**

**Make a huge impact on your lighting rig.** Moving-head light fixtures can add life to any club, or can give a stage the presence of a professional concert, and the Vizi LED Spot has the professional features required to do just that. With a long-life LED source and a low power draw, the Vizi LED Spot will live long after the tour is done.

**E. M520L 12" MIRROR BALL**

**Create a timelessly cool effect.** This dazzling effect combo includes a 12" mirror ball from American DJ, an AC mirror ball motor, two 30W UL-listed pinspots with lamps, and four color gels.

**F. MICRO GALAXIAN LASER**

**Micro-sized laser, larger-than-life show.** The Micro Galaxian produces more than 200 green and red laser beams that can be projected on a ceiling, wall, or dance floor. Operational modes include Auto Mode (built-in programs) and Sound Active. Built-in programs can be changed on the unit or from the included RF wireless remote.

**G. DYNO-FOG II FOG MACHINE**

**Create an instant environment in 5 minutes.** The American DJ Dyno-Fog II fog machine features a 1,000W heater and an output of 4,000 cubic feet per minute, with an outboard fog switch that makes it easy to add an instant environment. This medium-duty is affordable and has a warm-up time of only five minutes, and at only 10lb. it can be mounted almost anywhere.

**H. DUO STATION**

**One DMX controllers built in.** The Duo Station features two controllers in one - a basic 3-channel RGB LED controller and an 8-channel On/Off switching system. It has separate outputs on the rear control panel so that each side runs independently from the other. It's an ideal control solution for DJs, small clubs, and bars that want simple LED control.



For full selection, visit  
[musiciansfriend.com/american-dj](http://musiciansfriend.com/american-dj)

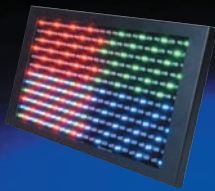

**A Profile Panel RGB**  
 485713 MSRP \$199.95 **\$149<sup>99</sup>**



**B Vertigo Tri LED**  
 581111 MSRP \$179.95 **\$99<sup>99</sup>**



**C 38B LED Pro DMX PAR Can**  
 808888 MSRP \$159.95 **\$99<sup>99</sup>**



**D P64 LED Plus PAR Can**  
 584287 MSRP \$219.95 **\$99<sup>99</sup>**



**E P36 LED DMX Pinpoint with RGB Color Mixing**  
 803198 MSRP \$104.90 **\$79<sup>99</sup>**



**F MyDMX Lighting Control Software**  
 801688 MSRP \$399.95 **\$299<sup>99</sup>**

**A. PROFILE PANEL RGB**

**Indoor LED panel with rich palette of color.** Works great as an architectural wall wash or on performance stages – without the uncomfortable heat. With 288 LEDs, it has 7 DMX channel modes and 4 operational modes, including built-in programs, sound mode, master/slave mode, and DMX mode.

**B. VERTIGO TRI LED**

**A classic American DJ effect, now with LED technology.** Adds sparkle with 32 sound-activated beams that move and strobe in a moonflower-like effect. 2 - 9W, 3-in-1 RGB tri-color LEDs (100,000-hr. rating) produce a variety of colors. In/out IEC power connections for daisy-chaining. Hanging yoke.

**C. 38B LED PRO DMX PAR CAN**

**Dazzling club effects with cool, energy-efficient LED technology.** 75 LEDs and 7 operational modes offer endless dance floor and stage excitement. With RGB mixing, the color choices are limitless. Brackets allow mounting or floor placement. LED Sync function auto-syncs with other LED effects. See our website for complete details.

**D. P64 LED PLUS PAR CAN**

**A large palette of colors with smooth RGB mixing.** Along with 151 ultrabright LEDs, it offers DMX-controlled, sound-activated, auto, and RGB operation modes. Works standalone or in a master/slave configuration. This long-life fixture also has electronic dimming, a color strobe effect, and emits almost no heat.

**E. P36 LED DMX PINSPOT WITH RGB COLOR MIXING**

**Very smooth projection with rich palettes of color.** Combines red, green, and blue LEDs to create any desired shade. Auto, Sound Active, or 6-channel DMX operation. Hanging bracket and tabletop metal stand included.

**F. MYDMX LIGHTING CONTROL SOFTWARE**

**Control all the DMX lighting fixtures in your set by using computer software.** Load MyDMX on your PC for simple yet creative control of your 512-DMX-compliant lights. It has a library of 2,000 profiles, an editor, 3D visualizer, MIDI triggering, effects generator, and works with simple scenes/steps. PC only.



For full selection, visit [musiciansfriend.com/chauvet](http://musiciansfriend.com/chauvet)



**A Geyser RGB Fogger Effect**  
H90529 MSRP \$599.99 **\$399<sup>99</sup>**



**B Comet LED**  
H71909 MSRP \$129.99 **\$89<sup>99</sup>**



**C Intimidator Scan LED 200**  
H71910 MSRP \$419.99 **\$349<sup>99</sup>**



**D D-Fi Wireless DMX Light**  
H81261 MSRP \$419.99 **\$259<sup>99</sup>**



**E Motion Drape TRI Color LED**  
H782120 MSRP \$839.99 **\$599<sup>99</sup>**



**F MotionFaçade LED**  
H782150 MSRP \$419.99 **\$299<sup>99</sup>**

**A. GEYSER RGB FOGGER EFFECT**

Amazing fogger effect illuminated with colorful LEDs. Make a statement with Geyser RGB — a unique effect that adds a touch of drama. This powerful fogger blasts a vertical stream of safe, water-based fog while simultaneously illuminating it with 21 high-power (3W) LEDs. A combination of red, green and blue LEDs allows you to easily mix the perfect color to illuminate the fog.

**B. COMET LED**

Quad-colored, sound-activated effect light. The Chauvet Comet LED uses red, green, blue, and white LEDs to shoot crisp beams of light across the room. This perfect party light has energetic, sound-activated programs that allow beams to dance to the beat without any programming.

**C. INTIMIDATOR SCAN LED 200**

Bright, compact LED scanner with tons of features. The Intimidator Scan LED 200 is a bright, compact LED scanner with tons of features including; built-in movement macros and move-in-black features; silent electronic dimming and strobe features; awesome sound-activated programs; and easy access to built-in automated programs capable of generating a completely synchronized show.

**D. D-FI WIRELESS DMX LIGHT**

Wireless RGB LED wash lighting fixture, with adjustable angle head. The Freedom Strip Par from Chauvet is a completely wireless system that combines an RGB LED wash fixture with the D-Fi wireless DMX system and battery power. With complete freedom from cables, you can place the Freedom Par anywhere in your entire rig, or around the room without the need to run cables from power sources.

**E. MOTION DRAPE TRI COLOR LED**

Beautiful controllable lighted backdrop for DJs. The MotionDrape LED is a backdrop for any mobile performer. 176 tri-color SMD LEDs matrixed across the 6.5ft by 9.8ft backdrop and can be controlled via the included controller or via DMX. This impressive display has 30 animated effects that range from color fades to a graphic equalizer effect.

**F. MOTIONFAÇADE LED**

Colorful LED skirting for the DJ booth. At 3.3ft by 6.5ft, the MotionFaçade LED makes a perfect front board for a DJ. Use it alone or use The MotionFaçade LED as a companion to the MotionDrape LED. 66 tri-color LEDs power 30 different effects which easily run in conjunction with the MotionDrape LED or on its own via the included controller or via DMX.



For full selection, visit  
[musiciansfriend.com/chauvet](http://musiciansfriend.com/chauvet)

**A** 4PLAY 6-Channel LED Light Bar  
 485511 MSRP \$289.99 **\$219<sup>99</sup>**



**A. 4PLAY 6-CHANNEL LED LIGHT BAR AND EFFECTS SYSTEM**

A ready-to-go lighting bar for the traveling entertainer. The bar is fitted with 4 LED moon-flowers, each containing 57 red, green, blue, and white LEDs that produce razor-sharp, rotating beams. Adjustable strobe speed plus 6-channel DMX, auto, and sound-active modes.

**B** COLORstrip DMX LED Linear Wash Light  
 801638 MSRP \$329.99 **\$199<sup>99</sup>**



**B. COLORSTRIP DMX LED LINEAR WASH LIGHT**

Daisy-chain up to 31 units for a killer runway effect. Wall or ceiling mountable for numerous lighting options. Built-in programs include sound active, standalone, master/slave, and 4-channel DMX-512 modes. Static colors and RGB color-mixing with or without controller.

**C** Followspot 400G with Stand  
 803086 MSRP \$709.96 **\$289<sup>99</sup>**



**C. FOLLOWSPOT 400G WITH STAND**

Put your act in the spotlight. This lighting equipment pack comes with the Followspot 400G, stand, and mounting bracket giving you everything you need to enhance your next show. Brilliant 2-channel DMX functionality with 7 dichroic colors will put your show in the spotlight.

**D** 4BAR LED System  
 817159 MSRP \$574.99 **\$399<sup>99</sup>**



**D. 4BAR LED SYSTEM**

4 LED washes in a super-portable, footswitchable system. This 15-channel DMX system includes a footswitch, adjustable tripod, packing bag, and transport case. Each of the 4 low-profile lights contains 108 red, green, and blue LEDs and can be independently positioned. Built-in automated and sound-activated programs are accessible with or without the footswitch.

**E** Color Bank  
 803107 MSRP \$84.99 **\$39<sup>99</sup>**



**E. COLOR BANK**

Turn the gym into a concert hall. This lightweight fixture offers four dazzling colors with fully automatic sound activation, chase, and low power consumption. Uses 4 CHR30 bulb. 19"W x 11-7/16"H x 14-3/4"D; 7lb.

**F** COLORstrip Mini  
 620639 MSRP \$169.99 **\$119<sup>99</sup>**



**F. COLORSTRIP MINI**

192 red, green, and blue LEDs for an exciting array of effects. This 19" effect delivers both static and RGB mixing with or without a DMX controller. Offers blackout, dimmer, and strobe options and has built-in automated and sound-activated programs operable through master/slave or DMX modes. Link up to 31 units for a great runway effect!

## How to Order

Web . . . . . [musiciansfriend.com](http://musiciansfriend.com)

Phone . . . . . 800-217-5207; En español: 800-249-8509  
 . . . . . 4:00 a.m.-11 p.m. PT

Mail . . . . . P.O. Box 7479 Westlake Village, CA 91359-7479  
 FAX . . . . . 818-735-7547

## Payment Options



- Some credit card orders must be shipped to the cardholder's address. All credit card orders are subject to verification prior to shipping.
- Check, cashier's check, or money order, made payable to Musician's Friend. Non credit-card orders may be subject to a 10 business-day hold.
- Western Union money transfer. Please call for information. Find a nearby Western Union agent location at [westernunion.com](http://westernunion.com) and ask for the "Blue Quick Collect Form" to get our reduced rate.
- Bill Me Later<sup>®</sup> and PayPal<sup>®</sup> available for web orders only.

## MSRP

Manufacturer's Suggested Retail Price ("MSRP") is the suggested retail selling price of a product provided to us by manufacturers. We may commonly sell products at prices lower than MSRP and, for any given product, no sales may have occurred at MSRP. MSRP is a benchmark to compare our discounts from MSRP to pricing offered by other retailers. Whether other retailers sell at MSRP will vary by product, geographic location, type of store, and over time. Although we periodically update the MSRPs posted in our stores, direct mail offerings, and on our website as we receive them, in some cases manufacturers may change a suggested retail price without notice to us. Please contact the manufacturer of a specific product for the most up-to-date MSRP information. MSRPs quoted for house or private label brands are developed internally in consideration of comparable name brand products. We may commonly sell such products at prices lower than MSRP and, for any given product, no sales may have occurred at MSRP. Although our limited time events are intended to be limited time events, our low prices offered during these events may continue in effect after the event.

## Limited Quantities

Some products, including those identified as Hot Buys, Closeouts, Limited Quantity items, Factory B-Stocks, and Free Gifts may be limited to stock on hand and are offered on a first come, first served basis.

## Mailing List

Our mailing list is occasionally made available to carefully screened companies whose products may be of interest to our customers. If you'd like your name and address removed from this shared list, please call our customer service center at 800-217-5207. Receiving duplicate catalogs? Send us all of the mailing labels and indicate which one is correct. Send to: *Musician's Friend, Customer Service, P.O. Box 1117, Draper, UT 84020-1117*. Please note that these requests may take up to eight (8) weeks to take effect, particularly if we are removing your name from our postal mailings.



## Warning

Certain products identified with this symbol  and offered for sale in this catalog contain a chemical known to the state of California to cause birth defects and other reproductive harm.

ITEM#	DESCRIPTION	QTY.	PRICE EA.	TOTAL

# FREE SHIPPING ON ALMOST EVERYTHING

Get Details Online At [musiciansfriend.com/shipping](http://musiciansfriend.com/shipping)

Products marked  may require truck freight and an additional charge. Products marked  may require an additional charge. **Purchase orders and orders to P.O. boxes are excluded.** Free shipping to APO/FPO restricted to limit of 70 lb. for each box. Other restrictions (same as domestic shipments) may also apply.

Please charge my:

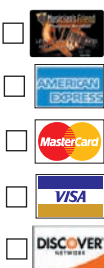

□□□□ - □□□□ - □□□□ - □□□□ □□ - □□

Account Number On Card

Exp. Date



Signature \_\_\_\_\_

CSV Code \_\_\_\_\_



**Musician's Friend offers Next Day Air, 2-Day Express, and Express Ground options – talk with your Customer Service Representative or visit us online for details and rates.**

As a security precaution, initial orders and orders shipping to alternate addresses may be held for extended verification.

## Delivery/Shipping

- Verified orders using Standard Ground Shipping to the Lower 48 states will be shipped no later than the next business day following order placement and will be delivered within 8 business days.
- As a security precaution, some orders may require extended verification.
- To make sure you get your gear as quickly as possible, your order may arrive in multiple boxes over multiple days, but you will not be charged more for shipping as a result.
- If in-stock items on the order have already shipped, back order items will be sent UPS Ground.
- Lighter weight items may be shipped via USPS and may not contain a tracking number. (This applies to Free Ground Shipping only.)
- Orders shipping outside the Lower 48 states to Hawaii, Alaska, and Puerto Rico can only be shipped via air services. Orders shipping to U.S. Military APO/FPO addresses, P.O. Boxes, and U.S. territories (Guam, Virgin Islands, etc.) are shipped by USPS (6-10 business days). International APO/FPO destinations may require additional delivery time. NOTE: Boxes over 70 lb. each cannot be shipped to these locations.
- We are not able to ship Yamaha products to Puerto Rico, Guam, or the Virgin Islands.
- For information about International Shipping, please visit our website.
- Special shipping conditions apply to items marked with the following symbols:
  -  Extra-large package. May require additional shipping charge.
  -  Due to FAA regulations item can ship via ground freight only.
  -  Item requires truck freight delivery due to size or weight and can ship to destinations in the Lower 48 states only.

## FREE SHIPPING ON ALMOST EVERYTHING

FREE shipping is valid on most shipments to the Lower 48 states. Free shipping to APO/FPO addresses is limited to 70 lb. per box and subject to the same restrictions as domestic deliveries. Orders will be shipped via ground shipping method. Products marked  may require truck freight and an additional charge. Products marked  may require an additional charge. **Purchase orders and orders to P.O. boxes are excluded.**

## Returns

Your satisfaction is guaranteed; if you need to return an item, please call us at 800-217-5207 for a Return Authorization.

## 45-DAY LOWEST PRICE GUARANTEE\*\*

Buy with confidence. If you find a lower advertised price from any authorized U.S. dealer, call or email us. We'll match any verifiable advertised price before or after the sale. If you've already purchased from us and find a lower advertised price within 45 days of your purchase, contact us via phone or email and we'll refund the difference after verification. Please write to [support@musiciansfriend.com](mailto:support@musiciansfriend.com) for email requests. Include the competing website address (preferably the product page URL) so that we may verify the competing offer.

\*\*Due to manufacturer restrictions, some products are excluded from this guarantee. Please ask a sales representative or email us at [support@musiciansfriend.com](mailto:support@musiciansfriend.com) for details. Advertised items must be factory-sealed new product. Demo models, seconds, discontinued products, and floor samples not included. Items must be advertised, in stock, and verifiable on the web or in a local or national paper, magazine, or catalog by an authorized dealer (you may be required to email or fax a copy of the competitor's offer). Musician's Friend will match combined or multiple offers at its sole discretion.

©2013 Musician's Friend, Inc., Westlake Village, CA.  
 Printed in the United States. All rights reserved.

## 45-DAY 100% SATISFACTION GUARANTEE\*\*\*

If you are not completely satisfied with any product, return it for a full refund of the product purchase price, full credit, or exchange – your choice. We give you 45 days from the shipping date. That's the best guarantee in the music industry.

\*\*\*The following items are returnable only if defective OR unopened or unused: strings, reeds, computers, tubes, earbuds, earplugs, recorders, tin whistles, flutophones, "world" wind instruments, harmonicas, raw-frame speakers, drumheads, drumsticks, turntable cartridges, fog fluid, clothing/footwear, body jewelry, sheet music, cleaners, polishes, and polishing cloths. Software/soundware, cassettes, CDs, DVDs, and videos may be returned for credit only if they are in their original, sealed packaging. If defective, these items will only be exchanged for the same product. Mouthpieces may be returned, but will incur a sterilization fee. Due to their return policies, you must contact Apple directly to repair, replace, or return Apple products. They may not be returned to us under any circumstance.

Stringed instruments priced at \$1,999.00 or more must be returned within 10 days of shipment. Please call or visit us online for details.

Musician's Friend accepts only returns made within the first 45 days from shipment. Should you find it necessary to return any merchandise, it must be shipped within this 45-day guarantee period. Please follow the return instructions printed on the back of your invoice. All returned items must include a Return Authorization Number, be in the original packaging complete with all components including the warranty card and owner's manual, and show no signs of wear or abuse; otherwise the return will either be refused or subject to a 15% restocking fee. See [musiciansfriend.com/shopping-guarantee](http://musiciansfriend.com/shopping-guarantee) for details. Credit card returns are issued a credit for purchase price. Refunds are made for product value only, excluding shipping and handling charges. We bring you the lowest possible prices; as such, offers are subject to change without notice. Prices in this catalog supersede all previous catalogs and may be superseded by future catalogs. Musician's Friend does not accept liability for printing errors, incorrect manufacturer's specifications, or grammatical inaccuracies. We reserve the right to refuse service to anyone. All items purchased from Musician's Friend are made pursuant to a shipment contract. This means that the risk of loss and title for such items passes to you upon our delivery to the carrier. For complete details on our guarantees, shipping, and return policies, please contact our Customer Service Department at 800-217-5207; fax us at 818-735-7547; visit us online at [musiciansfriend.com](http://musiciansfriend.com) or write us at Musician's Friend, P.O. Box 7479 Westlake Village, CA 91359-7479.

## GOLD COVERAGE

### PROTECT YOUR PURCHASE!

Now you can get added warranty protection for your new gear with Gold Coverage that steps in where the manufacturer's "normal wear and tear" ends. This plan extends and expands your coverage up to 3 years.

- In addition to normal wear and tear, Gold Coverage protects you against damage caused by spills, drops, impacts, dust, internal heat, humidity, heavy usage, even lightning and power surges.
- Gold Coverage is transferable from the original owner, adding value even if you plan to sell your gear down the road.
- No-Lemon Policy on gear over \$200 – if it fails for the same reason more than 3 times, it is replaced on the fourth breakdown.
- Complete refund in the event of failure or substandard performance on gear under \$200.
- Manufacturer's Specs Coverage: The product need not fail to be covered. If it does not perform as it did the first day you bought it, it will be repaired or replaced.
- Great service: The plan is administered by National Electronics Warranty Co. (NEW) offering 24-hour-a-day, toll-free professional services. Repairs are made only at factory-authorized service centers. In most cases, there's one in your nearest metropolitan area. If you're too far away, NEW pays the shipping!

For complete terms and conditions, please visit [musiciansfriend.com](http://musiciansfriend.com) or call 800-217-5207

To avoid shipping delays – If you are ordering by credit card for the first time from Musician's Friend, you can expedite your order by calling your credit card issuer and adding your "Ship To" address (if different from your regular billing address) to their records.

## BILLING ADDRESS

If your address is a P.O. Box, please provide a street delivery address.

name \_\_\_\_\_  
 address \_\_\_\_\_  
 city \_\_\_\_\_  
 state \_\_\_\_\_ zip \_\_\_\_\_  
 email address \_\_\_\_\_ phone \_\_\_\_\_

## SHIP TO

(if different from address above) If your address is a P.O. Box, please provide a street delivery address.

name \_\_\_\_\_  
 address \_\_\_\_\_  
 city \_\_\_\_\_  
 state \_\_\_\_\_ zip \_\_\_\_\_  
 email address \_\_\_\_\_ phone \_\_\_\_\_

All guitars on this page come with a Gibson gig bag or hardshell case



**A** Les Paul Studio Deluxe II '60s  
H90731 MSRP \$1,899.00 **\$1399<sup>00</sup>**



**B** Les Paul Traditional Pro II '60s Neck Iced Tea  
H89379 MSRP \$3,199.00 **\$1999<sup>00</sup>**



**C** Les Paul J  
H90746 **from \$699<sup>00</sup>**



**D** SGJ  
H90765 MSRP \$999.00 **\$599<sup>00</sup>**



**E** SG Standard  
H90750 MSRP \$2,039.00 **\$1299<sup>00</sup>**



**F** Les Paul '50s Tribute Min-ETune  
H90762 **from \$1199<sup>00</sup>**



H90723

**G** Les Paul Standard 2013 Premium Birdseye  
H90723 MSRP \$4,699.00 **\$3399<sup>00</sup>**

Les Paul Standard 2013 Premium Flame  
H90732 MSRP \$4,699.00 **\$3399<sup>00</sup>**

Les Paul Standard 2013 Premium Quilt  
H90740 MSRP \$4,699.00 **\$3399<sup>00</sup>**



Les Paul Standard 2013  
H90726 MSRP \$3,899.00 **\$2599<sup>00</sup>**



**H** Les Paul Standard Premium Plus  
H80024 MSRP \$3,899.00 **\$2999<sup>00</sup>**

**A. LES PAUL STUDIO DELUXE II '60s**

**A palette of powerful sounds.** Mounted on a carved maple top with a mahogany back, the 490R and Burstbucker Pro pickups offer coil-tapping via their push/push volume pots and a boost circuit with user-adjustable 10-dB boost is activated by rhythm tone control. It comes with Grover tuners and a tune-o-matic bridge. Heritage cherry sunburst finish shown; see more finishes online. Includes hardshell case.

**B. LES PAUL TRADITIONAL PRO II '60s NECK ICED TEA**

**The gigging musician's tool box of tone.** It has a non-chambered mahogany body with thick maple cap and Super '57 bridge and '57 Classic neck pickups. Features include antique binding, period-correct pickguard and top hat knobs. Get real coil-splitting and an active boost switch that make this Les Paul an icy cool tool box of tone. Ice tea.

**C. LES PAUL J**

**A lot of tone in one affordable package.** It features a mahogany back with "traditional" weight relief and a maple top. The maple neck has a rounded '50s profile for smooth play. A pair of Modern Classics humbuckers are designed to meet the needs of today's guitarist. It comes with a tune-o-matic bridge and vintage-style tuners. Cherry finish shown; see more finishes online.

**D. SGJ**

**Classic tonewoods and innovative hardware.** Here's a stripped-down, no-nonsense package with a cool, worn look. The body is solid mahogany with a slim '60s profile maple neck. It comes with 490R and 498T humbucking pickups in the neck and bridge and vintage-style tuners. All finishes feature a grain-textured nitrocellulose lacquer. Chocolate finish shown; see more finishes online.

**E. SG STANDARD**

**A revamped classic.** It has all of the classic SG appointments including a double-cutaway mahogany body, slim mahogany neck, bound rosewood fretboard, trapezoid inlays and Gibson's '57 Classic humbucking pickups, plus the original, smaller pickguard with tenon cover for the ultimate vintage-inspired look. Ebony finish shown; see more finishes online.

**F. LES PAUL '50s TRIBUTE MIN-ETUNE**

**A classic that's always in tune.** This one starts with the classic tonewood combination of a mahogany body with solid carved maple top. It has a pair of PAF-style BurstBucker humbucking pickups and a '50s profile mahogany neck. The Min-ETune system is hardly noticeable and tunes your guitar in just 3 seconds and 1 strum. Vintage sunburst finish shown; see more finishes online.

**G. LES PAUL STANDARD 2013**

**Meet the new standard of versatility.** Sporting a choice of maple tops, this year's model has a new neck profile, a compound-radius fingerboard, and stealth wiring for the BurstBucker Pro 1 & 2 pickups that provides individual coil-splitting, phase reversal, and pure bypass switching—all without changing its timeless beauty and vibe.

**H. LES PAUL STANDARD PREMIUM PLUS**

**Choice woods and modern electronics.** Here's a classic in your choice of a carved AAA figured maple top or a plain maple top (for solid colors) all on a mahogany back. It comes with Burstbucker Pro pickups fitted with coil-split capability, locking tuners, neck and body binding, and a '60s slim-taper neck with compound-radius.

# Martin & Co. 180 YEARS OF TRADITION



**A** GPCPA1 Plus Acoustic-Electric  
H83794 MSRP \$3,999.00 **\$2999<sup>00</sup>**

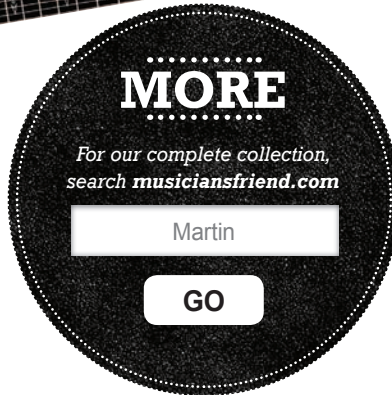

**B** D-28 Dreadnought  
514690 MSRP \$3,149.00 **\$2399<sup>00</sup>**



**C** 000-15SM  
H77730 MSRP \$1,849.00 **\$1399<sup>00</sup>**



**D** Custom X Series D12X1AE 12-String Acoustic-Electric  
H83042 MSRP \$819.00 **\$599<sup>00</sup>**



**E** DRS1 Acoustic-Electric  
H71014 MSRP \$999.00 **\$749<sup>00</sup>**



**F** 000X1AE Custom X Series Acoustic-Electric  
H81746 MSRP \$749.00 **\$499<sup>00</sup>**



**G** LX1E Little Martin Acoustic-Electric  
514513 MSRP \$519.00 **\$399<sup>00</sup>**

**A. GPCPA1 PLUS ACOUSTIC-ELECTRIC**  
**Strikingly state of the art.** The solid rosewood back and sides naturally resonate bass, while the solid Sitka spruce top has a clear and powerful tone. A two-ring pearl rosette, arrows and squares inlay, gloss finish and pickguard add distinguished touches. Fishman F1 Aura+ electronics amplify this Grand performer's tone. Natural finish. Includes Martin Deluxe Hardshell case.

**B. D-28 DREADNOUGHT**  
**The standard in steel-string guitars.** A classic since its 1931 debut, it has a solid Sitka spruce top with glossy finish, special East Indian rosewood for the back and sides, and ebony for the fingerboard and bridge. With its resonant warmth and punchy volume, it's well-suited to music styles requiring loud, powerful rhythm accompaniment. Natural finish shown; sunburst add \$200. Includes Martin deluxe hardshell case.

**C. 000-15SM**  
**An instant classic.** This small-bodied guitar harkens back to a time before the invasion of the dreadnought. It has an all-mahogany body with slotted headstock, a real rosette, improved inlays and nickel tuners with butterbean knobs. Its 12-fret body design delivers plenty of woody tone and volume, in spite of its size. Includes Martin deluxe hardshell case.

**D. CUSTOM X SERIES D12X1AE 12-STRING ACOUSTIC-ELECTRIC**  
**Spectacular 12-string articulation.** This one has high pressure laminate (HPL) mahogany back and sides with a solid Sitka spruce top with custom rosette and factory installed Fishman electronics. Easy access volume and tone controls are conveniently and strategically located just inside the sound hole. Natural with solid sitka spruce top.

**E. DRS1 ACOUSTIC-ELECTRIC**  
**For working guitarists on a budget.** This dreadnought has a top, back and sides of solid sapele and is braced for resonance and projection. It features a multilaminar Stratabond neck and Richlite belly bridge and fingerboard. It comes with the Fishman Sonitone sound reinforcement system discreetly mounted in the soundhole. Natural finish. Includes Martin hardshell case.

**F. 000X1AE CUSTOM X SERIES ACOUSTIC-ELECTRIC**  
**Medium-sized and low-priced.** Pairing a solid Sitka spruce top with a custom rosette and mahogany-grained high pressure laminate (HPL) back and sides, this one has a surprisingly robust sound in spite of its compact body. Stage-ready, it's equipped with out-of-view Fishman electronics that maintain the look of a veritable and elegant Martin. Natural finish.

**G. LX1E LITTLE MARTIN ACOUSTIC-ELECTRIC**  
**Comfortable, portable and distinctively Martin.** This small travel and student guitar has a solid Sitka spruce soundboard atop the small, modified 0-14 body. Fishman Isys T electronics let you electrify your sound. Includes Morado fretboard and bridge, 23" scale, low-oval neck and Martin's mortise/tenon neck joint. Gotoh nickel tuners. Natural finish. Includes Martin gig bag.



### Roto Blues Electric Guitar Strings Light Top/Heavy Bottom

Gauges 10-13-17-30w-42w-52w. Nickel  
101177 MSRP \$9.50 **\$5<sup>95</sup>**



### Coated Electric Guitar Strings Light

10-13-17-26-36-46 10-46 9-42  
100941 MSRP \$19.00 **\$12<sup>99</sup>**



### 2223 Nickel Super Slinky Electric Guitar Strings

Gauges 9-11-16-24w-32-42. 9-42  
100621 MSRP \$8.50 **\$3<sup>89</sup>**



### Nanoweb Electric Medium Strings

11-14-18-28-38-49 11-14-18-28-38-49  
101539 MSRP \$19.50 **\$10<sup>79</sup>**

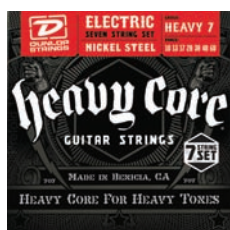

### Heavy Core 7-String Electric Guitar Strings - Heavy Gauge

H74969 MSRP \$13.50 **\$6<sup>49</sup>**

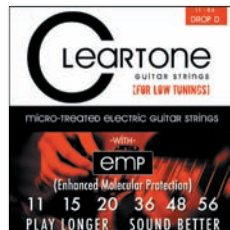

### Drop Tune Electric Guitar Strings Drop D

Gauges: 11-15-20p-36-48-56  
107006 MSRP \$19.00 **\$12<sup>99</sup>**



### 2721 Cobalt Regular Slinky Electric Guitar Strings

H79095 MSRP \$17.00 **\$9<sup>99</sup>**



### Boomers Medium Electric Guitar Strings 10-Pack

11-15-18-26-36-50 Gauges: 11-50.  
484896 MSRP \$97.55 **\$38<sup>99</sup>**



### Nickel Plated Steel Electric Guitar Strings Light 6 Pack

Gauges: 9-42  
713144 MSRP \$57.24 **\$24<sup>99</sup>**

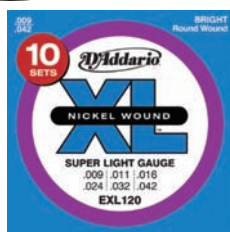

### EXL120 Nickel Super Light Electric Guitar Strings 10-Pack

The string for those who like to strrrrrrretch their notes. Gauges  
9-11-16-24-32-42.

H71082 MSRP \$84.50 **\$31<sup>99</sup>**



### 2620 Power Slinky Nickel Wound 7-String Electric Guitar Strings

11-14-18p-28-38-48-58  
100641 MSRP \$10.80 **\$6<sup>39</sup>**



### VR9 Vintage Reissue Pure Nickel Electric Guitar Strings

09-11-16-24-32-42  
102279 MSRP \$10.99 **\$6<sup>87</sup>**



### S1046 Power Nickel Strings

Gauges: 10-13-17-26PW-36-46  
100813 MSRP \$7.95 **\$4<sup>19</sup>**

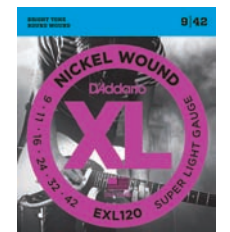

### EXL120BT Balanced Tension X-Lite Electric Guitar Strings Single-Pack

H93015 MSRP \$9.90 **\$4<sup>99</sup>**



### Electric 9 Nickel-Plated Steel Electric Guitar Strings

101808 MSRP \$8.99 **\$1<sup>99</sup>**



### 2552 Blue Steel Light Electric Guitar Strings

Gauges: 9-11-16-24-32-42 09-42  
101050 MSRP \$12.95 **\$5<sup>99</sup>**



### Aspire Accents Cajon

Hardwood front playing surface with a solid hardwood body. Large rubber feet and adjustable snare wires. 17-1/2"H x 12"W x 11-3/4"D. See available finishes online.

584577 **from \$154<sup>99</sup>**

### Mario Cortes Cajon

Handmade in Spain from select birch. Internal wire snare strands add high-end sizzle to the conga-like highs and powerful lows. 19"H x 12"W x 12"D.

443285 MSRP \$461.00 **\$300<sup>00</sup>**

### Journeyman Cajon

Perfect if you're on the move and you need a great sounding cajon that can take a beating night after night. The combination of the fiberglass frame with a wood frontplate produces a robust, unique and low-ended tone with great projection.

H82916 MSRP \$356.00 **\$229<sup>99</sup>**



### Aspire Series Timbale Set

With drumkit-style tuning. Characteristic timbale sound projects well to cut through even the loudest bands. Includes an Aspire cowbell, cowbell holder, and key. 13" and 14" diameters with 6" shells.

440634 MSRP \$356.00 **\$229<sup>99</sup>**

### Aspire Conga Set

10 and 11" oak congas with chrome hardware and double stand. Quality hardware and curved rims offer precise head tuning and ergonomic play. Choose vintage sunburst (shown), natural, red wood or dark wood finish.

440641 MSRP \$419.00 **from \$299<sup>99</sup>**

**TOP DEALER EXCLUSIVE**



### Giovanni Compact Conga

**Great for practice and tight spaces.** Built in an aluminum-alloy frame and a synthetic head for tuning stability. It can be played onstage, in studio or anywhere quiet practice is necessary or a full-sized conga is impractical. Choose 11" or 11-3/4".

447711 **From \$175<sup>99</sup>**



### Performer Conga 3-Pack with Bongos

**A quintet of quality hand drums for one low price.** Siam oak 11" quinto, 11-3/4" conga, and 12-1/2" tumba from the Performer Series along with free 6-3/4" and 8" bongos. EZ-Curve rims are comfortable to play. Choose red fade (shown), green fade, black/natural, vintage sunburst, natural, blue fade or dark wood finish.

7201150 **\$549<sup>99</sup>**

**TOP DEALER EXCLUSIVE**



### Stanton Moore Pandeiro

This 12" pandeiro is made to use with a drum set, and mounts on any stand with a standard 3/8" rod. The hardwood shell is made to withstand the impact of playing with sticks. Includes a carrying bag.

H71820 MSRP \$167.00 **\$108<sup>99</sup>**



### LP760A Percussion Table

**A must-have for the pro percussionist.** The 22"W x 19"D tabletop has a rubber surface to protect your instruments and permit quiet handling. Includes 2 height-adjustable cross bars with up to 24

positions, 6 rods, 3 triangle hooks and more.

440535 MSRP \$464.00 **\$219<sup>99</sup>**



### Tito Puente Thunder Timbale Set

**A rich sounding, volume-heavy timbale!** Oversized 10" deep bronze shells with 15 and 16" diameter heads offer boosted volume and bass. Includes a height-adjustable steel stand, adjustable cowbell bracket,

timbale sticks, and more.

441234 MSRP \$1,038.00 **\$679<sup>00</sup>**



### Conga Shaker Trio

**A trio of conga-themed shakers with varying volumes.** The Conga Shaker Trio includes multi-colored shakers

with particular volume levels and in a patented design. Filled with non-toxic steel shot.

H81922 MSRP \$14.99 **\$8<sup>99</sup>**



### Twist Shakers

**A re-invented version of LP's often-imitated softshaker.** A set of twin dumbbell-shaped shakers connected with a rotating lock mechanism that allows them to be played together or individually. Available in three volumes.

H80899 MSRP \$25.99 **\$15<sup>99</sup>**



### Egg Shaker Trio

**A trio of egg shakers for any venue.** These Egg Shaker sets include three shakers, each featuring a particular volume level and color. Filled

with non-toxic steel shot.

H88933 MSRP \$11.99 **\$6<sup>99</sup>**



### Qube Shaker

Play like a normal shaker with a back and forth motion, or with a spin of the wrist for complex rhythms. Choose studio or the slightly louder live version.

H71815 **From \$19<sup>99</sup>**



**TOP DEALER EXCLUSIVE**

### Tambourine & Cowbell with Mount Kit

An all-inclusive set with a US-made, lively LP City cowbell, a sensitive and durable LP Cyclops tambourine and an ergonomic mounting arm.

H74450 MSRP \$114.00 **\$39<sup>99</sup>**



### Vibra-Slap II Deluxe

**One of the most recorded sound effects.** Strike the ball end against your palm for warm crisp tones. Sound is varied by

rotating the wooden sound chamber.

440620 MSRP \$78.00 **\$50<sup>99</sup>**

**RhythmTech**



**Ribbon Crasher**  
Choose 11" or 15".  
620017 **from \$34<sup>99</sup>**



**Pro Torq Drum Key**  
440701 MSRP \$40.95  
**\$11<sup>59</sup>**



**Studio Cowbell with Mount**  
No-slip mount included.  
581652 MSRP \$69.00  
**\$29<sup>99</sup>**



**Mountable Gig Tray**  
446691 MSRP \$68.95  
**\$47<sup>99</sup>**



**Ergonomic Tambourine**  
Choose black, white, blue, red, yellow or purple.  
460010 **from \$27<sup>99</sup>**



**Solo Tambourine**  
Choose cobalt blue, purple, white, red or black.  
446690 **from \$13<sup>99</sup>**



**True Color Tambourine**  
Choose 8" or 10" white, red, yellow, cobalt blue or black.  
446694 **from \$7<sup>99</sup>**



**RT8000 Cabasa**  
460102 MSRP \$49.95  
**\$29<sup>99</sup>**



**Drum Kit Pack**  
446463 MSRP \$111.95  
**\$59<sup>99</sup>**



**Drum Kit Pack 2**  
500345 MSRP \$111.95  
**\$69<sup>99</sup>**



**Studio Shaker**  
Choose 5" or 9".  
440740 **from \$10<sup>99</sup>**

**NEW**



**Hat Shake G2**  
H94667 MSRP \$40.95  
**\$26<sup>99</sup>**



**Solo Energy Chime**  
H94686 MSRP \$23.00  
**\$11<sup>99</sup>**



**Energy Chime**  
Choose three tone, 5 tone add \$13.  
H80601 **from \$19<sup>99</sup>**



**Tre35 Classic Aluminum Chimes**  
440521 MSRP \$200.00  
**\$119<sup>99</sup>**



**Studio Tree 44 Thin Single Row Bar Chime**  
444990 MSRP \$225.00  
**\$134<sup>99</sup>**

*Schalloch*  
Percussion



**Wood Bongo Set**  
Choose brown, vintage sunburst, blue fade, natural, super natural, wine red or tequila sunrise.  
444771 **from \$69<sup>99</sup>**



**Rope-Tuned Djembe**  
Choose XS, S, M, L or XL.  
447006 **from \$29<sup>99</sup>**



**Cyclone drum**  
H71568 MSRP \$20.99  
**\$12<sup>99</sup>**



**Tambourine with Calfskin Head**  
Choose 8" or 10".  
445665 **from \$13<sup>99</sup>**



**Double-Row Tambourine 10 inch**  
445663 MSRP \$19.95  
**\$13<sup>99</sup>**



**Economy Tambourines**  
Single or double row jingles. Choose 6", 8" or 10".  
467927 **from \$13<sup>99</sup>**



**Samba Choro Pandeiro with Brass Jingles**  
Goat brown with 10 in x 1.78 in.  
H14081 MSRP \$212.25  
**\$130<sup>99</sup>**

# PRICE DROPS | FREE GIFTS | REBATES & MORE

SAVE  
\$350



**BREEDLOVE**  
Revival D/SMe Burst Acoustic-Electric Guitar  
Vintage vibe meets stage-ready electronics.  
H85557 MSRP \$1,129.00 ~~\$849.00~~ **\$499<sup>00</sup>**

SAVE  
\$400



**BREEDLOVE**  
Atlas Revival OM/ERe Ab Acoustic-Electric Guitar  
Pre-war style with modern sound.  
H85572 MSRP \$1,339.00 ~~\$799.00~~ **\$599<sup>00</sup>**

SAVE  
\$8



**ON-STAGE STANDS**  
Deluxe Single Guitar Stand  
Improved protection with thicker tubing and die-cast leg housing.  
H73749 MSRP \$29.99  
~~\$17.95~~ **\$9<sup>95</sup>**

SAVE  
\$3



**HOHNER**  
BIP Blue Ice Harmonica,  
3 Pack with Zippered  
Carrying Case  
Cool sounds in the keys of C, G and D.  
H90353 MSRP \$18.00  
~~\$12.99~~ **\$9<sup>99</sup>**

SAVE  
\$26



**EVANS** EC1 Coated Fusion Drumhead Pack  
More balanced tone and clearer pitch.  
482375 MSRP \$96.25 ~~\$45.99~~ **\$19<sup>99</sup>**

SAVE  
\$245



**PRS**  
SE Santana  
Orange finish  
PRS quality with tone from  
clean to crunch.  
H69094 MSRP \$1,115.00  
~~\$724.00~~ **\$479<sup>00</sup>**

SAVE  
\$245



**PRS**  
SE Santana  
black finish  
A familiar silhouette.  
H69094 MSRP \$1,069.00  
~~\$694.00~~ **\$449<sup>00</sup>**

SAVE  
\$50



See online for  
more finishes

**IBANEZ** GRG150MS Electric Guitar  
Available in Black Night, Candy Apple, Yellow, and White.  
H77130 MSRP \$357.13 ~~\$249.99~~ **\$199<sup>99</sup>**

SAVE  
\$60



**IBANEZ**  
IJAE5 JamPack Jolt/SE  
Acoustic-Electric  
Guitar Pack  
Comfortable Ibanez playability plus  
amp and accessories for under \$200.  
519605 MSRP \$399.99  
~~\$249.99~~ **\$189<sup>99</sup>**

Visit our Deal Center online at [musiciansfriend.com/dealcenter](http://musiciansfriend.com/dealcenter)

# DEAL CENTER

## SPOTLIGHT



SAVE \$200

**KUSTOM Profile 100 Portable PA System**  
Quality performance and convenient features in a highly transportable package.

486077 MSRP \$599.00 ~~\$399.99~~ **\$199<sup>99</sup>**

SAVE \$20



**AKG K 44 MKII Headphones**  
Designed for critical listening.

620620 MSRP \$79.99  
~~\$49.99~~ **\$29<sup>99</sup>**

SAVE \$170



**VOCOPRO UHF-5805 Plus**  
Rechargeable Wireless System with Mic Bag  
4 rechargeable mics means the party never has to stop. Includes mic bag.

H74920 MSRP \$679.00 ~~\$469.99~~ **\$299<sup>99</sup>**



SAVE \$200

**KUSTOM Profile 200 Portable PA System**  
Portable PA system with integrated 200W, 6-channel mixer and 2 - dual 6-1/2" speakers

486078 MSRP \$799.00  
~~\$499.99~~ **\$299<sup>99</sup>**

\$100 PRICE DROP



while supplies last

**YAMAHA MM6 Synthesizer Workstation**  
Bold MOTIF sounds in a very affordable package.

700813 MSRP \$699.00 ~~\$499.99~~ **\$399<sup>99</sup>**

SAVE \$30



**MXL 990/991 Package**  
Your one-stop mic kit for vocals, drum overheads, acoustic guitars, and more.

273166 MSRP \$299.95  
~~\$99.95~~ **\$69<sup>95</sup>**

SAVE \$300



while supplies last

**CASIO PX-3S 88-Key Digital Stage Piano**  
Designed for professional performances.

H81223 MSRP \$999.99 ~~\$799.99~~ **\$499<sup>99</sup>**

SAVE \$200



**ART PRO MPA II Reference Series**  
A low-noise, high-quality, limited-edition tube pre that won't break the bank.

H72096 MSRP \$459.00 ~~\$399.99~~ **\$199<sup>99</sup>**

SAVE \$10



**MUSICIAN'S GEAR Tripod Mic Stand with 20' Mic Cable (3-Pack)**  
Perfect for the band on a budget.

H77700 MSRP \$359.82  
~~\$49.99~~ **\$39<sup>99</sup>**

Many more deals online. Visit [musiciansfriend.com/dealcenter](http://musiciansfriend.com/dealcenter)



MF Advertising  
PO Box 4283  
Woodland Hills, CA 91367-4283

Presorted Standard  
US Postage Paid  
Musician's Friend, Inc.

OR CURRENT RESIDENT

Customer # Source Code



**MUST USE YOUR PERSONAL COUPON CODE ABOVE**

**EXCLUSIVE CATALOG OFFER**

**ENDS  
6/15/13**

**15% OFF  
SINGLE ITEM \$49+**

Some brands have opted to not participate in our offers.  
Call us at 800-217-5207 or see [www.musiciansfriend.com/pages/special-offer-details](http://www.musiciansfriend.com/pages/special-offer-details)



SAVE \$50

MXL 870

H87200 MSRP \$259.99 ~~\$199.99~~  
**\$149.99**



\$229 PRICE DROP

EON510 Powered PA Speaker

501163 MSRP \$779.00 ~~\$629.00~~  
**\$399.99**



\$30 INSTANT REBATE

MXL 990/991 Package

273166 MSRP \$299.95  
~~\$99.99~~ Before Rebate **\$69.99** After Rebate



SAVE \$50

KeyStudio Keyboard

H65531 ~~\$129.99~~ **\$79.99**



\$100 PRICE DROP

PRX612M

H05528 MSRP \$1299.00 ~~\$799.00~~  
**\$699.00**

PRX615M

H05530 MSRP \$1449.00 ~~\$899.00~~  
**\$799.00**



SAVE \$30

PSR E333

H73355 MSRP \$269.00 ~~\$159.99~~  
**\$129.99**



JUST \$4.99 EACH

20' Lo-Z Mic Cable (10-Pack)

338006 MSRP \$299.00 **\$49.99**



NEW

Reason 7

H95539 MSRP \$449.00 **\$399.00**



**FREE SHIPPING** on almost everything | 150% Price Match | 45-Day Best Fit Promise

Shop [musiciansfriend.com](http://musiciansfriend.com) | Call 800-217-5207 | Para español 800-249-8509

Scan this code with your smart phone to shop online. Free app available at [getscanlife.com](http://getscanlife.com)

**1306T**